



YAMARIN 67 DAY CRUISER

Owner's Manual



Table of Contents

1 Introduction.....	5
1.1 About this manual.....	5
1.2 Copyright and disclaimer.....	6
1.3 Warranty.....	7
1.4 Contact information.....	7
2 Safety.....	8
2.1 Owner's responsibilities.....	8
2.1.1 Registration and insurance.....	8
2.1.2 Training and experience.....	8
2.1.3 Maintenance and care.....	9
2.1.4 Before setting off.....	9
2.2 Warning symbols.....	10
2.3 Safety labels.....	11
2.3.1 Helm station and deck area.....	12
2.3.2 Cabin.....	16
2.3.3 Transom and windshield.....	18
2.4 Fire-fighting and fire protection.....	20
2.4.1 Fire extinguishers.....	20
2.4.2 Installing fire extinguishers.....	21
2.5 Carbon monoxide.....	22
2.5.1 Carbon monoxide monitoring system.....	23
2.6 Person overboard prevention and recovery.....	24
3 Basic information.....	25
3.1 Builder's plate.....	25
3.2 Design categories.....	25
3.3 Technical specifications.....	26
3.3.1 Specification details.....	26
3.3.2 Measurements for antifouling paint area	28
4 Structural characteristics.....	29
4.1 Stability and buoyancy.....	29
4.2 Openings in the hull and deck.....	29
4.3 Seating areas.....	29
4.3.1 Designated seats.....	30
4.4 Doors, gates and hatches.....	30
4.4.1 Windshield door.....	30
4.4.2 Cabin door and stairs to the deck.....	30

5 Operation.....	32
5.1 Helm station controls.....	32
5.1.1 Control device locations.....	32
5.1.2 User instructions for controls.....	33
5.2 Driving.....	33
5.2.1 Emergency cut-off switch.....	33
5.2.2 Approaching and leaving the dock.....	34
5.2.3 Visibility from the steering position.....	35
5.2.4 Driving at high speed.....	36
5.2.5 Operating the joystick.....	36
5.2.5.1 Integrated bow thruster controller.....	38
5.2.6 Adjusting the trim tabs.....	40
5.2.6.1 Trim system components.....	41
5.3 Mooring, anchoring and towing.....	41
5.3.1 Attachment points.....	43
6 Fuel system.....	44
6.1 Fuel system components.....	44
6.2 Refueling and maintenance.....	45
6.3 Fuel-operated equipment.....	45
6.3.1 Fuel-operated equipment components	46
6.3.2 Heater.....	46
6.3.3 Stove.....	46
7 Engine.....	48
7.1 Starting engine.....	48
7.2 Using gearshift and throttle.....	48
8 Electrical system.....	49
8.1 System description.....	49
8.2 Main switch and fuse panel.....	49
8.2.1 Switch and fuse descriptions.....	50
8.3 Double-battery system.....	52
8.4 Maintaining batteries.....	52
8.5 Electrical equipment.....	53
8.5.1 Locations of electrical equipment.....	54
8.5.2 Shore power.....	55
8.5.2.1 Connecting shore power.....	55
8.5.3 Cabin lights.....	55
8.5.4 Navigation lights.....	56
9 Bilge pumps and draining.....	57
9.1 Electric pump.....	57

9.2 Manual pump.....	58
9.3 Locations of draining equipment.....	58
10 Freshwater system.....	59
10.1 Freshwater system components.....	60
11 Accessories.....	61
11.1 Toilet and septic tank.....	61
11.1.1 Septic system components.....	61
11.2 Anchor winch.....	62
11.2.1 Anchor winch system components.....	62
11.2.2 Using the anchor winch.....	62
11.3 Bow thruster.....	63
11.4 Canopy.....	64
11.5 Bimini.....	64
11.5.1 Raised bimini.....	65
12 Environmental considerations.....	66
12.1 Requirements for North America.....	66
12.2 Aquatic invasive species (AIS).....	66
13 Maintenance, repairs and docking.....	68
13.1 Maintenance tasks.....	68
13.1.1 Before winter lay-up.....	68
13.1.2 Before launching.....	68
13.2 Care instructions.....	69
13.2.1 Washing and waxing the boat.....	69
13.2.1.1 Fiberglass surfaces.....	69
13.2.1.2 Aluminium surfaces.....	70
13.2.1.3 Stainless steel surfaces.....	70
13.2.1.4 Plastic surfaces.....	70
13.2.1.5 Windshield.....	70
13.2.2 Marine upholstery.....	71
13.2.3 Storing the canopy.....	71
13.2.4 Adjustable seats.....	72
13.2.5 Electronic remote control device.....	72
13.2.6 Steering system.....	72
13.2.7 Electrical components.....	73
13.3 Trailer transportation and lifting.....	73
13.3.1 Placement on the trailer.....	75
14 Related documents.....	76

1 Introduction

1.1 About this manual

The purpose of this owner's manual is to help you use your boat in a safe and enjoyable way. The manual includes detailed information about the boat and its equipment and accessories, as well as instructions for use and correct maintenance of the boat. Read the manual carefully and familiarize yourself with your boat before using it.

This owner's manual alone is not a sufficient source of information on seamanship and boating safety, nor is this manual a detailed service and troubleshooting guide.



It is your responsibility to ensure that you have the basic boating skills and that the boat is used safely and maintained properly.

For more details about the owner's responsibilities, see [2 Safety](#) on page 8.

Conventions used in this manual:

- The units of measurement refer to the International System of Units (SI).
- In some cases, other units may have been added in brackets. If other units of measurement are used, they are always calculated from the original SI unit value.
- Wind speed is an exception to this rule: the Recreational Craft Directive uses the Beaufort scale to indicate wind speed. For consistency, this manual uses the same scale.



Retain this manual and provide it to the next owner in case you sell your boat.

Your authorized dealer:

Table 1.1 Record of ownership

1st owner	Year of purchase:	Domicile:
First and last name:		
2nd owner	Year of purchase:	Domicile:
First and last name:		
3rd owner	Year of purchase:	Domicile:
First and last name:		
4th owner	Year of purchase:	Domicile:
First and last name:		
5th owner	Year of purchase:	Domicile:
First and last name:		

1.2 Copyright and disclaimer

Copyright Inha Works Ltd. All rights reserved.

This owner's manual is protected by copyright controlled by Inha Works Ltd. This manual may not be reproduced wholly or in part without prior written authorization by Inha Works Ltd. Handing this material over to third parties without the prior written consent of Inha Works Ltd. is not allowed.

The material in this manual is for information purposes only.

The material in this manual has been translated from the original language.

Inha Works Ltd. reserves the right to make changes to its product range and to the models, colours, equipment, and technical solutions of its boats without prior notification. The boat's dimensions, weights, performance, and volumes may differ slightly for production-related technical reasons.

Standard equipment may vary by market. Make sure that the boat and the boat's equipment correspond to your order before accepting the delivery.

1.3 Warranty

A warranty is granted for the boat and the factory-installed equipment under the terms and conditions. Warranty documents are delivered with your boat. It is important that you read the warranty document and this manual before you use your boat the first time.

For optional equipment, the manufacturer of the equipment is directly responsible for the warranty. The boat is supplied with separate warranty documents for this equipment.

For all other warranty issues, contact your dealer.

1.4 Contact information

Manufacturer:

Inha Works Ltd.

Hahdenniementie 2

FI-21120 Raisio

Finland

For any enquiries, contact your local dealer.

2 Safety

2.1 Owner's responsibilities

As the owner of the boat, you are responsible for safety at all times.

In order to guarantee a pleasant and safe boating experience with your new boat, make sure that you have the necessary training and experience and keep your boat in good condition.

Make sure your boat is equipped with all appropriate safety equipment in accordance with the boat type and weather conditions. In some countries, equipment such as life vests, paddle, ropes, anchor, fire extinguishers and safety harnesses may be compulsory. If your boat is equipped with a life raft, study the instructions carefully.



You are also responsible for the safety of your crew. Make sure that:

- The crew is familiar with the correct use and operation of all safety equipment in the event of an emergency, including rescuing a person who has fallen overboard.
- Everybody wears a buoyancy aid, life jacket, or a boating vest on the deck. In some countries national boating regulations require that everyone aboard wears a personal floatation device whenever on board.

Study carefully and internalize the details in this *Safety* section of the manual.

2.1.1 Registration and insurance

In some countries it is mandatory to register boats of your boat type. Furthermore, operating the boat may be subject to qualification and/or minimum age requirements. Before you begin using the boat, find out whether it needs to be registered or if it is subject to any other official requirements.

Depending on the policy, a boat insurance may cover damage that occurs during the use of the boat, in transportation or during dry-docking. If you intend to lift the boat, check that your insurance also covers this.

Insurance can increase safety by giving you a peace of mind: in the event of an accident, you can concentrate on saving lives rather than property. Detailed information on insurance policies is available from insurance providers.

2.1.2 Training and experience

Safe operation of a boat requires prior training and practice. If this is your first boat or if the boat type is not familiar to you, it is particularly important that you obtain sufficient experience in handling and using the boat before you assume the responsibility of a boat master:

- Always remember to adjust the speed and direction of the boat to correspond to the wind and sea conditions.
- Check that the expected wind and sea conditions match the design category of your boat.
- Ensure that you and your crew are able to navigate the boat in the conditions that may arise.

Your boat dealer, local boating clubs and national motor boat and sailing associations can provide you with more information about local training in boating and recommend qualified instructors.

Books and courses provide good preliminary skills, but mastery of boat handling, navigation, mooring and anchoring requires many years of practice.



In some countries, a permit or authorisation may be required to operate the craft and special regulations concerning boats or boating may apply.

2.1.3 Maintenance and care

Always keep your boat in a good condition. A careful use of the boat is part of responsible seamanship.

Be careful to observe any signs of wear caused by age or due to heavy use or abuse. Any boat, no matter how strong it is, may sustain severe damage if used inappropriately.

If you have any questions related to the maintenance of your boat, contact your local dealer. Only use the services of repair companies recommended by your local dealer.



Modifications that affect the safety features of the boat may only be performed with the builder's written authorisation. The builder assumes no responsibility for unauthorised modifications.

2.1.4 Before setting off

Familiarize yourself with this owner's manual and always check at least the following items before leaving.

Weather conditions and forecast

- Take the wind, waves, and visibility into account. Close all the hull windows and hatches during use to prevent water incursion.
- Make sure that the design category, size and equipment of your boat, as well as the skills of the driver and crew are adequate for the area and expected weather conditions.

Loading and stability

- Do not overload the boat.
- Distribute loads appropriately. Do not place heavy items high up.
- Check that there is no water in the bilge.
- Consider that the stability of the boat is reduced if people stand up when on board.
- Check that all the drain holes are open.

Passengers

- Ensure that there is a personal floatation device or life jacket for all people on board.
- Agree crew tasks before setting off.

Fuel and fuel system

- Make sure that the boat has enough fuel. Keep in mind that rough conditions at sea have an impact on fuel consumption, and that it can increase by more than 30% when compared to calm conditions.
- As a rule of thumb, aim for there being at least 20% left in the tank when arriving at your destination.
- Check that there are no fuel leaks.

Engine and manoeuvring equipment

- Check the functioning and condition of steering, batteries and remote control.
- Carry out routine checks according to the engine manual.
- For additional instructions concerning the engine, see the engine manual.

Loose equipment

- Check that all equipment and heavy items are positioned so that they stay in place during travel at sea and high winds.
- Note that the seat cushions may fly overboard if they are not fixed properly with press studs.

Nautical charts

- If you are not navigating in familiar waters, ensure you have nautical charts that cover a large enough area.
- If your boat is equipped with a chartplotter, familiarize yourself with it before setting off. Ensure that the charts are of the latest edition.
- Always keep a paper chart on board, even if you have a chartplotter.

Leaving the berth

- Agree with the crew about responsibilities for tasks, for example, who will release each mooring line.
- Be careful not to let mooring lines or the anchoring line tangle in the propeller during manoeuvring.

Mandatory equipment

- Check that all safety equipment is on board and up to date.
- What is considered mandatory varies from country to country. Find out what is required for your boat.

2.2 Warning symbols

This manual includes symbols highlighting important information. Heed the warnings and cautions according to the following severity:



Imminent hazard which **will lead to death or serious injury** if not avoided.

⚠ WARNING

Risk of hazard which **could lead to death or serious injury** if not avoided.

NOTICE

Situation which **might lead to property damage or in an unwanted result** if not avoided.



Call for attention.

2.3 Safety labels

The boat has safety labels in dedicated places. Make sure that you familiarize yourself with these labels and their meaning.

To replace a broken safety label, contact your local boat dealer and refer to this manual.

2.3.1 Helm station and deck area

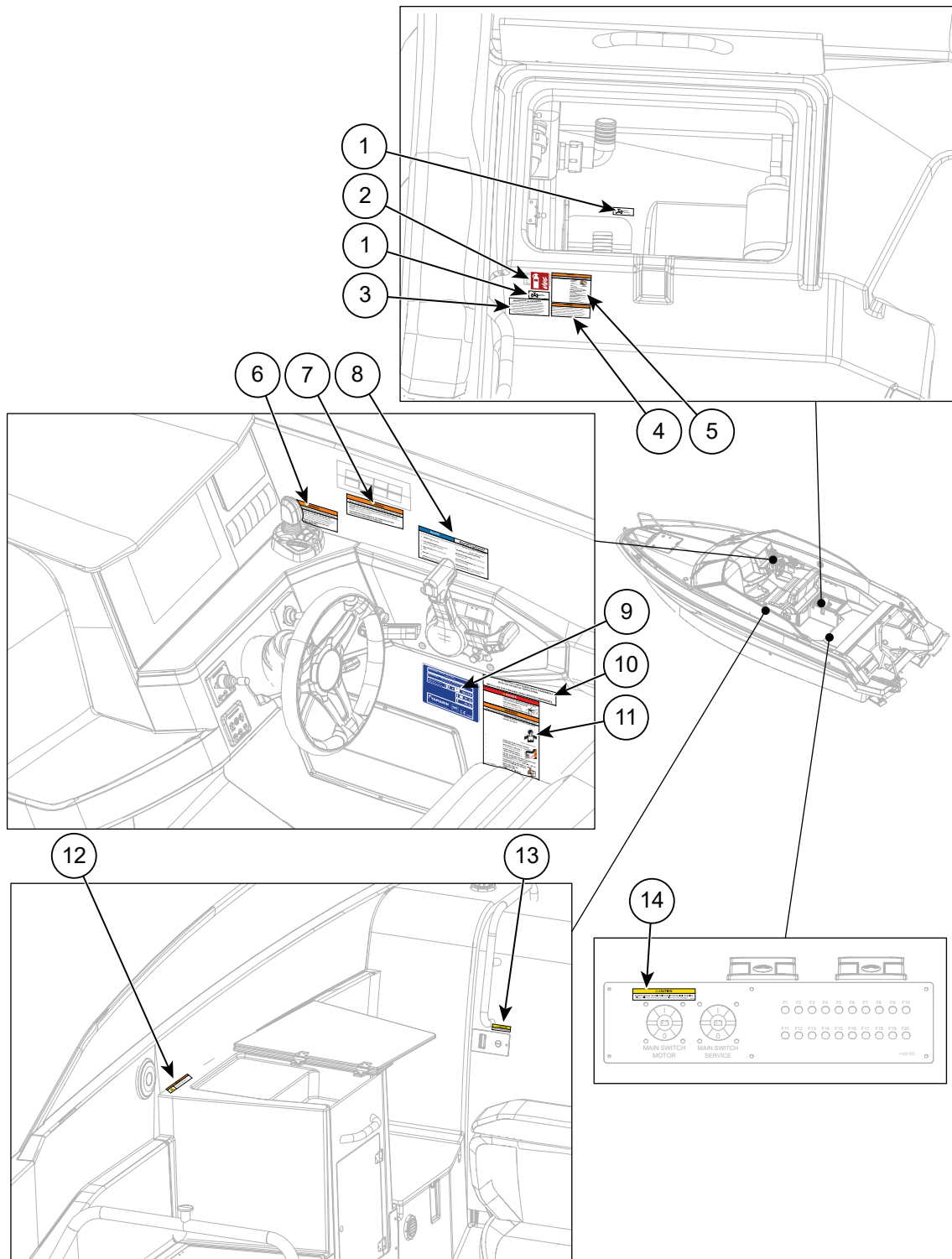

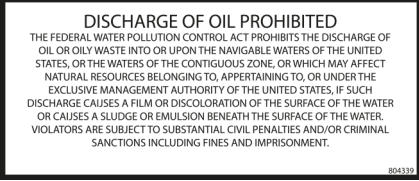
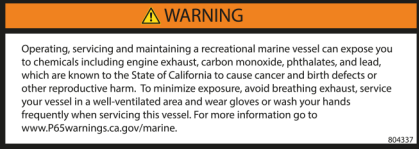
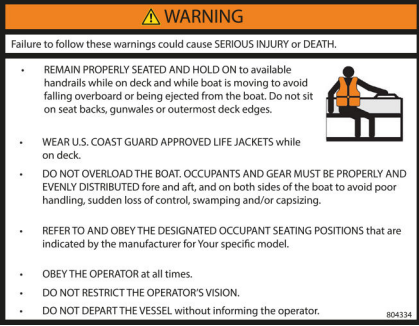
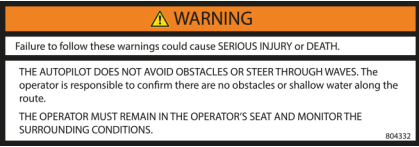
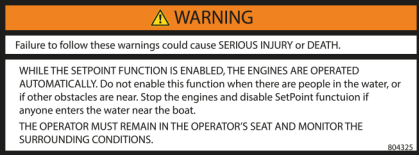
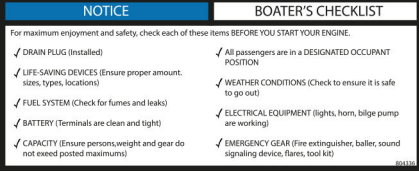
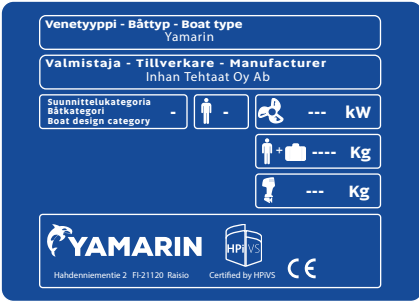

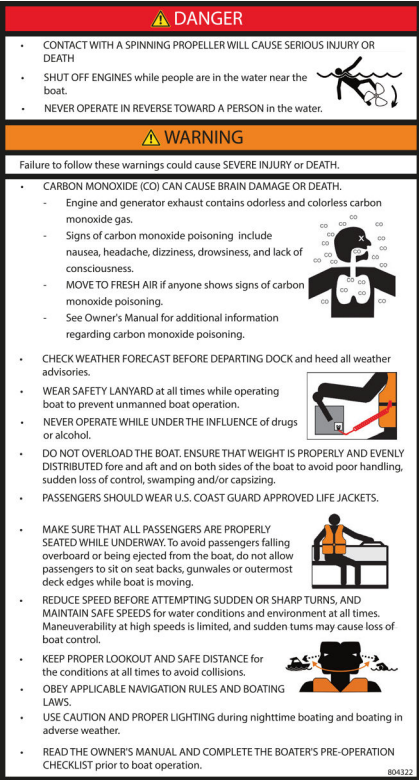





Figure 2.1 Helm station and deck safety labels

1		Waste tank shutoff valve label	804330
2		Fire extinguisher symbol	YMYS
3		Oil discharge prohibited label	804339
4		P65 warning label	804337
5		Deck combined warning label	804334
6		Autopilot warning label	804332
7		Setpoint warning label	804325

<p>8</p>	 <p>NOTICE BOATER'S CHECKLIST</p> <p>For maximum enjoyment and safety, check each of these items BEFORE YOU START YOUR ENGINE.</p> <ul style="list-style-type: none"> ✓ DRAIN PLUG (Installed) ✓ LIFE-SAVING DEVICES (Ensure proper amount, sizes, types, locations) ✓ FUEL SYSTEM (Check for fumes and leaks) ✓ BATTERY (Terminals are clean and tight) ✓ CAPACITY (Ensure persons, weight and gear do not exceed posted maximums) ✓ All passengers are in a DESIGNATED OCCUPANT POSITION ✓ WEATHER CONDITIONS (Check to ensure it is safe to go out) ✓ ELECTRICAL EQUIPMENT (lights, horn, bilge pump are working) ✓ EMERGENCY GEAR (Fire extinguisher, bailer, sound signaling device, flares, tool kit) 	<p>Boater's checklist</p>	<p>804336</p>
<p>9</p>	 <p>Venetyyppi - Båttyp - Boat type Yamarin</p> <p>Valmistaja - Tillverkare - Manufacturer Inhan Tehtaat Oy Ab</p> <p>Suunnittelukategoria Båtkategori Boat design category</p> <p>--- kW</p> <p>--- Kg</p> <p>--- Kg</p> <p>YAMARIN Haldenniemietie 2 FI-21120 Raisio</p> <p>HPi V5 Certified by HPi V5 CE</p>	<p>Builder's plate</p>	
<p>10</p>	 <p>THIS BOAT COMPLIES WITH U.S. COAST GUARD SAFETY STANDARDS IN EFFECT ON THE DATE OF CERTIFICATION</p> <p>MEETS U.S. EPA EVAP STANDARDS USING CERTIFIED COMPONENTS</p>	<p>EPA compliance label</p>	<p>804362</p>
<p>11</p>	 <p>⚠ DANGER</p> <ul style="list-style-type: none"> CONTACT WITH A SPINNING PROPELLER WILL CAUSE SERIOUS INJURY OR DEATH SHUT OFF ENGINES while people are in the water near the boat. NEVER OPERATE IN REVERSE TOWARD A PERSON in the water. <p>⚠ WARNING</p> <p>Failure to follow these warnings could cause SEVERE INJURY or DEATH.</p> <ul style="list-style-type: none"> CARBON MONOXIDE (CO) CAN CAUSE BRAIN DAMAGE OR DEATH. <ul style="list-style-type: none"> Engine and generator exhaust contains odorless and colorless carbon monoxide gas. Signs of carbon monoxide poisoning include nausea, headache, dizziness, drowsiness, and lack of consciousness. MOVE TO FRESH AIR if anyone shows signs of carbon monoxide poisoning. See Owner's Manual for additional information regarding carbon monoxide poisoning. CHECK WEATHER FORECAST BEFORE DEPARTING DOCK and heed all weather advisories. WEAR SAFETY LANYARD at all times while operating boat to prevent unmanned boat operation. NEVER OPERATE WHILE UNDER THE INFLUENCE of drugs or alcohol. DO NOT OVERLOAD THE BOAT. ENSURE THAT WEIGHT IS PROPERLY AND EVENLY DISTRIBUTED fore and aft and on both sides of the boat to avoid poor handling, sudden loss of control, swamping and/or capsizing. PASSENGERS SHOULD WEAR U.S. COAST GUARD APPROVED LIFE JACKETS. MAKE SURE THAT ALL PASSENGERS ARE PROPERLY SEATED WHILE UNDERWAY. To avoid passengers falling overboard or being ejected from the boat, do not allow passengers to sit on seat backs, gunwales or outermost deck edges while boat is moving. REDUCE SPEED BEFORE ATTEMPTING SUDDEN OR SHARP TURNS, AND MAINTAIN SAFE SPEEDS for water conditions and environment at all times. Maneuverability at high speeds is limited, and sudden turns may cause loss of boat control. KEEP PROPER LOOKOUT AND SAFE DISTANCE for the conditions at all times to avoid collisions. OBEY APPLICABLE NAVIGATION RULES AND BOATING LAWS. USE CAUTION AND PROPER LIGHTING during nighttime boating and boating in adverse weather. READ THE OWNER'S MANUAL AND COMPLETE THE BOATER'S PRE-OPERATION CHECKLIST prior to boat operation. 	<p>Helm station combined warning label</p>	<p>804322</p>

12	 <p>⚠ WARNING</p> <p>FIRE HAZARD KEEP THE PANTRY COVER PLATE IN OPEN POSITION, WHEN THE STOVE IS HOT.</p> <p>804321</p>	Hot stove warning label	804321
13	 <p>⚠ CAUTION</p> <p>KEEP SHUT WHILE UNDERWAY</p> <p>804323</p>	Keep shut caution label	804323
14	 <p>⚠ CAUTION</p> <p>DO NOT TURN OFF THE MAIN SWITCH WHILE THE ENGINE IS RUNNING! Failing to follow this instruction can cause alternator to be damaged.</p> <p>804324</p>	Main switch caution label	804324

2.3.2 Cabin

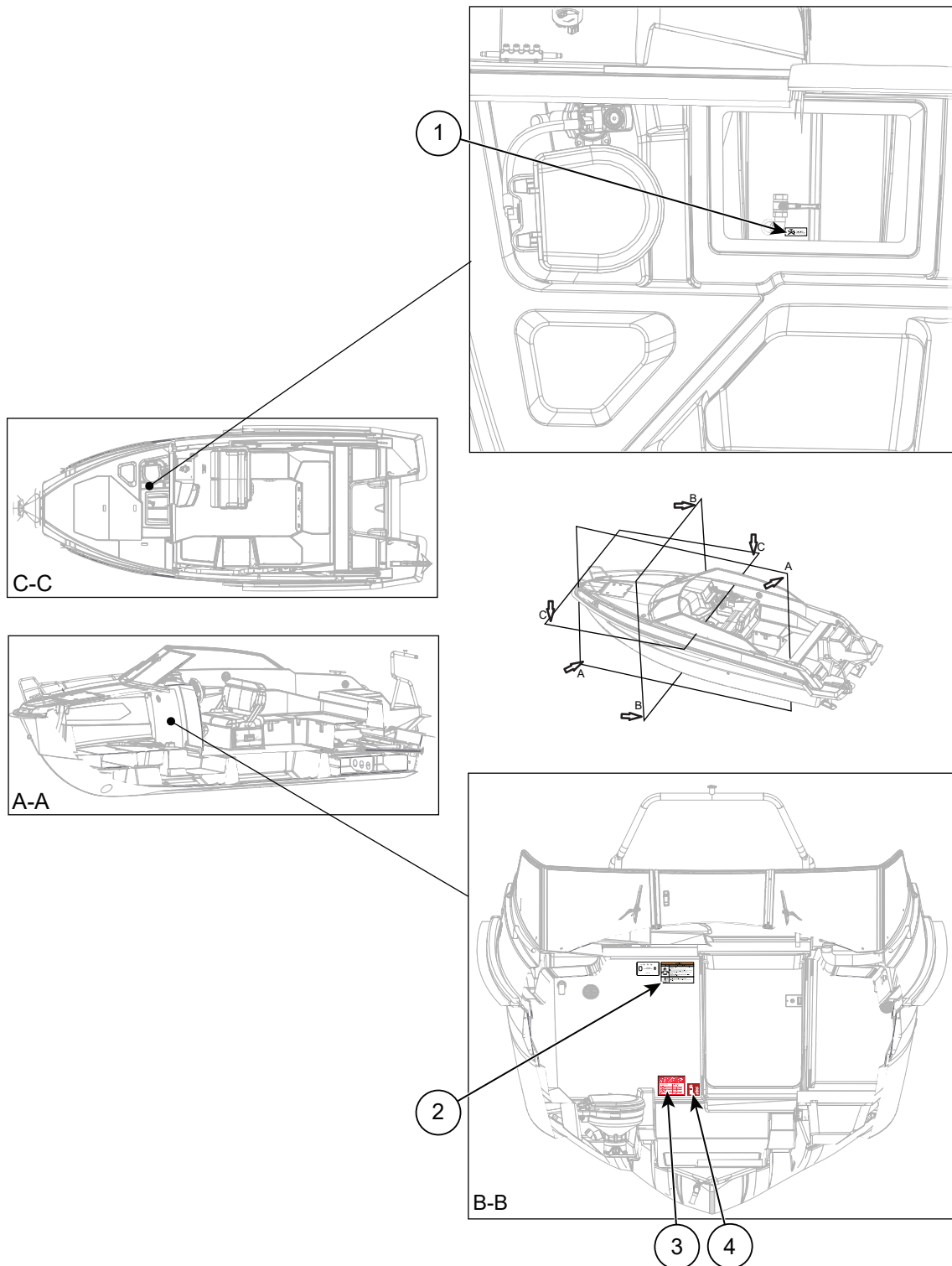

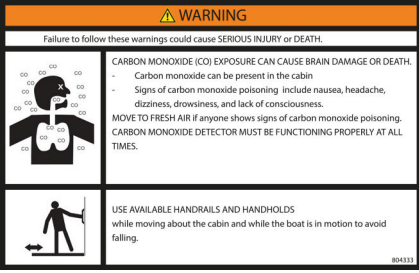
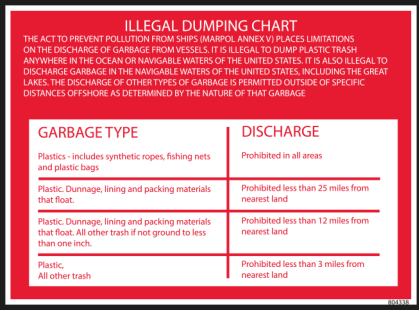



Figure 2.2 Cabin safety labels seen from left side (A), front (B) and above (C)

1		Toilet inlet shutoff valve label	804328										
2		Cabin combined warning label	804333										
3	 <table border="1" data-bbox="272 683 692 992"> <thead> <tr> <th>GARBAGE TYPE</th> <th>DISCHARGE</th> </tr> </thead> <tbody> <tr> <td>Plastics - includes synthetic ropes, fishing nets and plastic bags</td> <td>Prohibited in all areas</td> </tr> <tr> <td>Plastic Dunnage, lining and packing materials that float.</td> <td>Prohibited less than 25 miles from nearest land</td> </tr> <tr> <td>Plastic Dunnage, lining and packing materials that float. All other trash if not ground to less than one inch.</td> <td>Prohibited less than 12 miles from nearest land</td> </tr> <tr> <td>Plastic. All other trash</td> <td>Prohibited less than 3 miles from nearest land</td> </tr> </tbody> </table>	GARBAGE TYPE	DISCHARGE	Plastics - includes synthetic ropes, fishing nets and plastic bags	Prohibited in all areas	Plastic Dunnage, lining and packing materials that float.	Prohibited less than 25 miles from nearest land	Plastic Dunnage, lining and packing materials that float. All other trash if not ground to less than one inch.	Prohibited less than 12 miles from nearest land	Plastic. All other trash	Prohibited less than 3 miles from nearest land	Illegal dumping chart	804338
GARBAGE TYPE	DISCHARGE												
Plastics - includes synthetic ropes, fishing nets and plastic bags	Prohibited in all areas												
Plastic Dunnage, lining and packing materials that float.	Prohibited less than 25 miles from nearest land												
Plastic Dunnage, lining and packing materials that float. All other trash if not ground to less than one inch.	Prohibited less than 12 miles from nearest land												
Plastic. All other trash	Prohibited less than 3 miles from nearest land												
4		Fire extinguisher symbol	YMYSA										

2.3.3 Transom and windshield

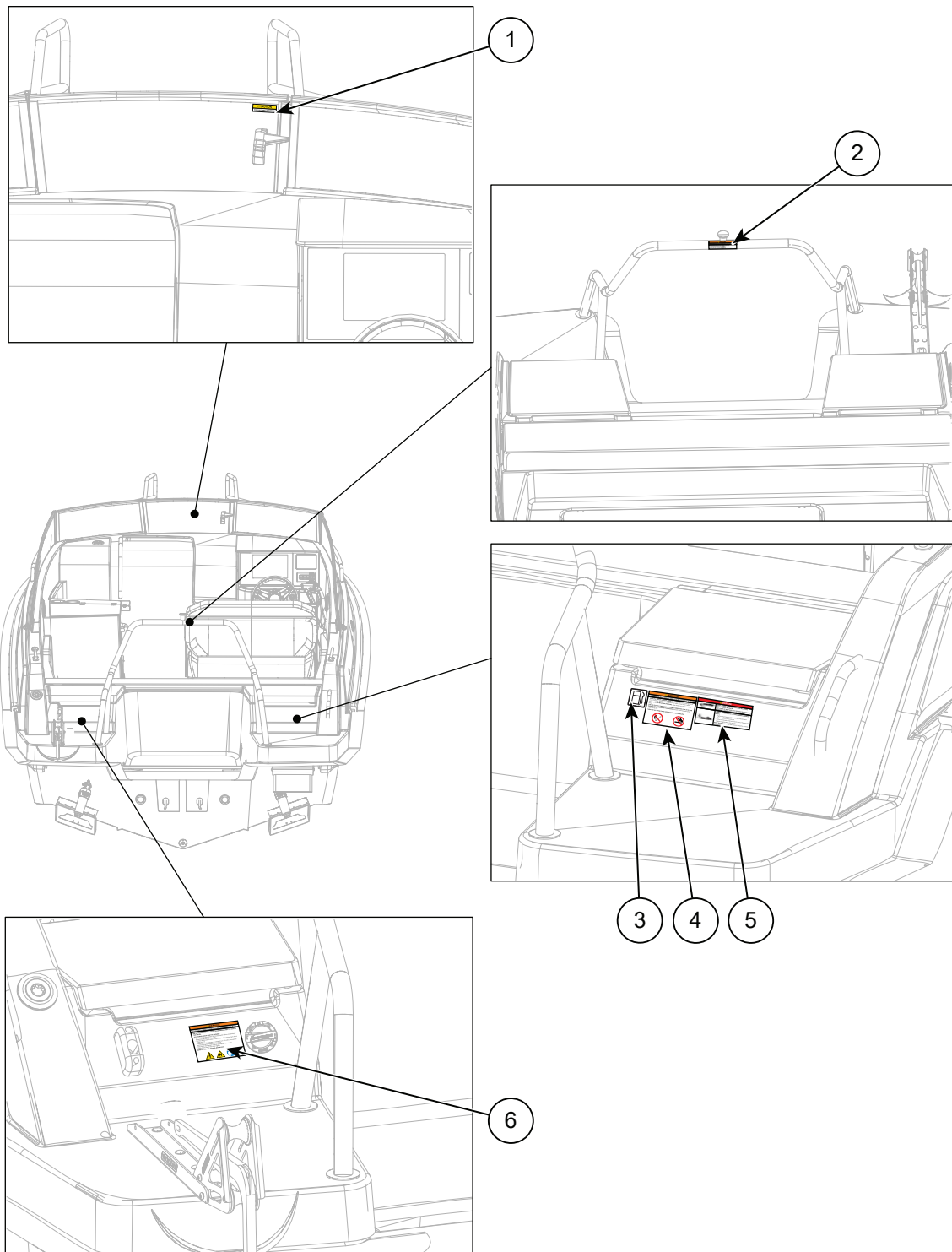

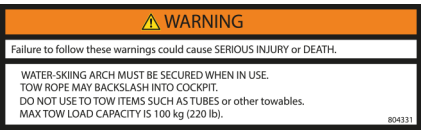

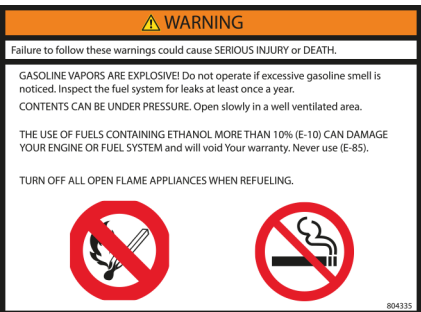
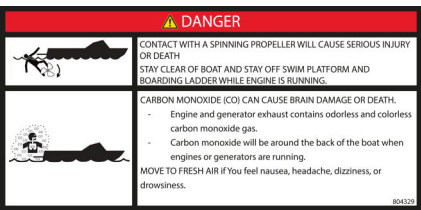
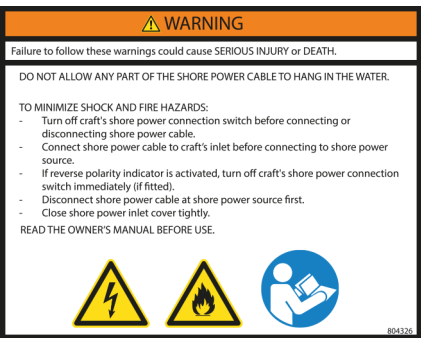

Figure 2.3 Transom and windshield safety labels

1		Keep shut caution label	8O4323
2		Water skiing arch warning label	8O4331
3		Fuel tank inlet symbol	YMY1PA02000
4		Fuel inlet warning label	8O4335
5		Transom combined warning label	8O4329
6		Shore power warning label	8O4326

2.4 Fire-fighting and fire protection

You are responsible for fire protection for the boat. Ensure that the following items are in order at all times when using the boat.

- All fire-fighting equipment is always easily accessible, whether the boat is empty or loaded.
- All crew members know the location and correct operation of the fire-fighting equipment.
- Make sure that no fuel spills into the bilge.
- Check the boat for fuel leaks at regular intervals. The smell of petrol is a clear sign of a fuel leak.

WARNING

Fire hazard systems

Improper use of the fuel or electrical systems may cause fire or explosion and lead to death or serious injury .

Never block access to safety equipment such as the fire extinguisher or the main switch for the electrical system. Ensure that the storage space for the fire extinguisher is unlocked when you use the boat.

Never cover the ventilation openings of the boat designed for the ventilation of fuel fumes.

Never alter the boat's electrical or fuel systems or allow an unqualified person to modify any of the boat's systems.

Never fill the fuel tank or handle fuel when the engine is running.

Never smoke or use a naked flame when handling fuel.

2.4.1 Fire extinguishers

The boat must be equipped with two UL classified 5-B:C (or greater) hand-held fire extinguishers that are tested by a US Coast Guard-recognized independent laboratory and marked "Marine Type – USCG Approved".

The location of the fire extinguishers is marked by a symbol, see [2.3 Safety labels](#) on page 11.



You are responsible for checking regularly that each fire extinguisher is up to date and in serviceable working condition. Make sure that:

- The current date does not exceed the cylinder date stamp by more than 12 years. You must remove the fire extinguisher from service no later than December 31 of the 12th year.
- If a pressure gauge is applied, the reading or indicator must be in the operable range.
- The operating handle lock pin is firmly in place.
- The spray nozzle is clean and free from obstructions.
- The extinguisher has no visible signs of significant corrosion or damage.



Be aware that the fire extinguishers are not included in the manufacturer's delivery. Consult your local boat dealer for further information.

2.4.2 Installing fire extinguishers

The boat has two dedicated places for the fire extinguishers.

- One in the cabin, under the deck stairs by the toilet
- One in the deck area, in the driver side seat box

These places are marked with fire extinguisher symbols. For the location of the symbols see section [2.3 Safety labels](#) on page 11.



All measurements are in millimeters.

To install the fire extinguishers, you need a suitable fire extinguisher bracket and wood screws. The bottom of the stairs has a 10 mm plywood reinforcement where the extinguisher is installed.

To install the cabin extinguisher:

- Drill pilot holes to the plywood for the bracket screws.
- Attach the bracket to the bottom of the stairs using wood screws.
- Attach the extinguisher to the bracket and make sure it stays firmly in place and easily accessible.

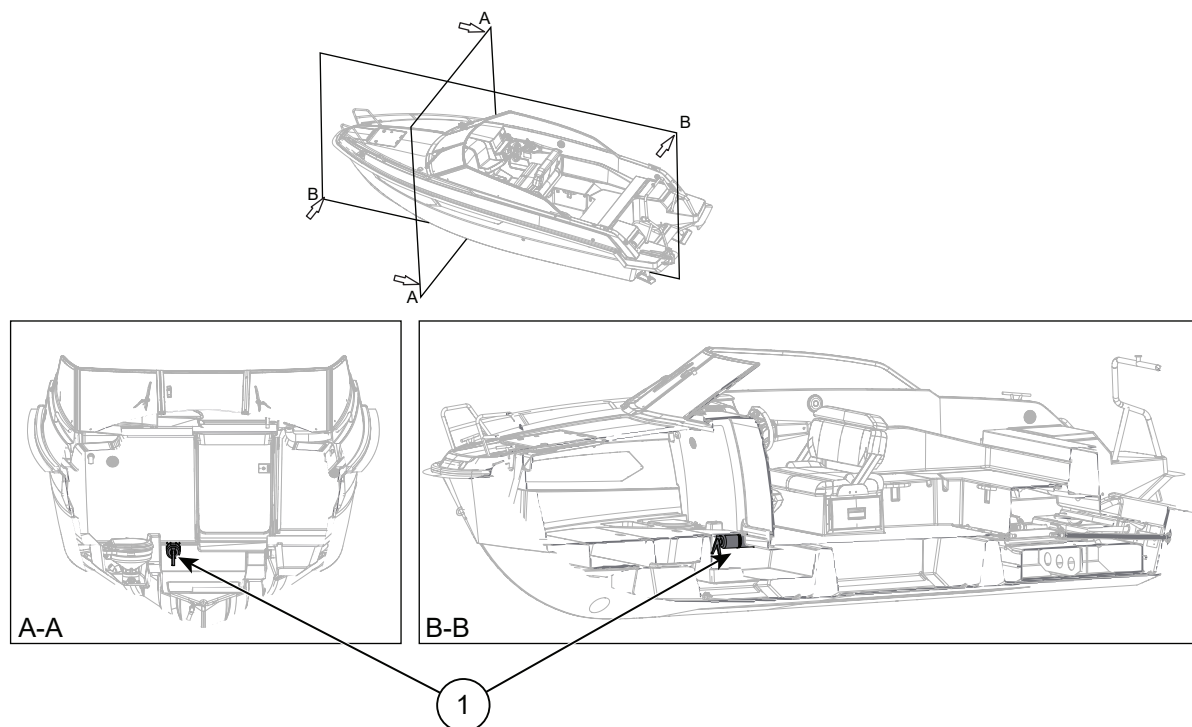

Figure 2.4 Location of cabin fire extinguisher seen from the bow (A) and left side (B)

- 1 Fire extinguisher

The bottom of the driver side seat box has a 10 mm plywood reinforcement where the extinguisher is installed. The plywood is laminated in the glass fibre and hidden from direct view. For the exact location of the plywood, see the picture below.

To install the driver seat box extinguisher:

- Drill pilot holes for the bracket screws to avoid cracking the glass fiber surface.
- Attach the bracket to the plywood using wood screws.
- Attach the extinguisher to the bracket and make sure it stays firmly in place and easily accessible.

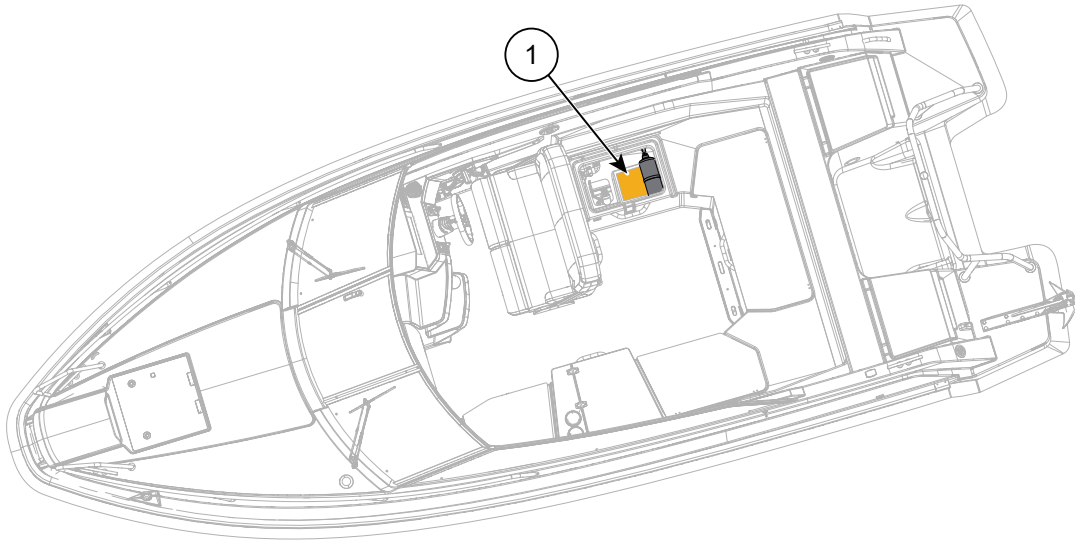

Figure 2.5 Location of driver seat box fire extinguisher

- 1 Plywood reinforcement

2.5 Carbon monoxide

Carbon monoxide (CO) is a colorless, odorless and tasteless gas that is unlikely to be noticed until a person is affected. All fuel burning engines and appliances produce carbon monoxide as exhaust.

⚠ WARNING

Carbon monoxide hazard.

Prolonged exposure to low concentrations or short exposure to high concentrations of CO can lead to brain damage or death.

Make sure that fresh air can circulate freely throughout the boat.

If the CO alarm activates, ensure that all persons onboard exit the closed spaces.

The symptoms of CO poisoning include nausea, headache, dizziness, ringing in ears and unconsciousness. A poisoned person's skin often turns cherry red. If you suspect CO poisoning:

- Immediately move the person to a well-ventilated area and have them breath fresh air deeply.
- If the person stops breathing resuscitate.
- Be aware that the person often revives, but then relapses due to an organ failure caused by the lack of oxygen. If this happens, seek immediate medical attention.

Preventing carbon monoxide accumulation

There is always a risk of carbon monoxide accumulation when you run the engine, generator or fuel burning appliances.

Dangerous amounts of carbon monoxide can accumulate if:

- The engine or generator exhaust systems leak or the hull exhausts are blocked or submerged while operating at slow speed.
- Insufficient fresh air is circulating where people are present.
- You run the engine or generator in a confined space.
- Wind blows exhaust fumes toward boat occupants or into the cockpit and cabin areas.
- You operate the boat with the bow high or use canvas curtains.

To minimize the danger of CO accumulation:

- Open all doors, curtains, windows, and hatches to let fresh air circulate while you run the engine, generator or fuel burning devices while the boat is anchored, moored or docked.
- Make sure you have sufficient ventilation when you use canvas or window-type side curtains.
- If you use a convertible top, make sure you operate the boat with the forward hatch and cabin door open.
- Do not use fuel burning appliances, such as charcoal, propane, LPG, CNG, or alcohol cookers, in areas with no noticeable fresh air circulation when anchored, moored or docked. This applies especially to the cabin area.
- Do not idle the engine without moving the boat for more than 15 minutes at a time.
- Inspect the exhaust system regularly for defects. See the manufacturer's manual for instructions.

2.5.1 Carbon monoxide monitoring system

The boat must be equipped with a battery-operated carbon monoxide monitor.

- Check regularly that the monitor is functioning. See the equipment manufacturer's manual for instructions.
- Do not turn off the monitor when you use the boat.

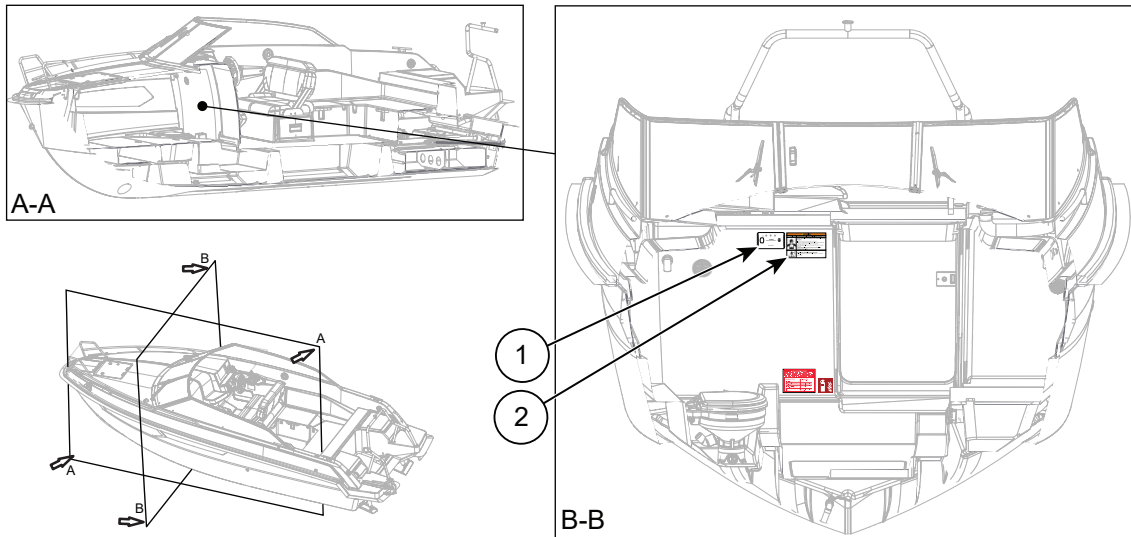

Figure 2.6 Placement of CO monitor seen from left side (A) and the bow (B)

- 1 CO monitor (in the cabin, by the toilet next to the warning label)
- 2 Cabin warning label

2.6 Person overboard prevention and recovery

To prevent falling overboard, do not stand or occupy any other area than the seats, when the boat is in motion. See [4.3 Seating areas](#) on page 29 for the seats designated for passengers.

In the event of falling overboard, use the swim ladder located on the transom to reboard the boat safely. You can angle down the ladder from within the water.

3 Basic information

3.1 Builder's plate

The builder's plate is mounted near the steering console.

Some of the information on the builder's plate is found in the [3.3 Technical specifications](#) on page 26. Detailed information that supplements the information provided on the plate is given in the relevant sections of this manual.

In addition to the boat model, the builder's plate contains important information about:

- Design category defining the limitations of use.
- Maximum load and number of persons allowed on board.

3.2 Design categories

Design categories define the most severe weather conditions in which the boat has been designed to be operated.



Design category is an important safety classification that must be respected. Always ensure that:

- The expected wind and sea conditions match the design category of your boat.
- You and your crew are able to navigate the boat in the conditions that may arise
- The boat is well maintained.

For each category, the conditions are given in the form of maximum wind force and significant wave height.

"Significant wave height" refers to an average height based on the highest one-third of the wave profile, corresponding roughly to the wave height observed by an experienced mariner. Individual waves may be twice as high.

All Yamarin boats belong to design category B, C or D.

Your boat's design category is given in [3.3 Technical specifications](#) on page 26 in this manual, and on the Builder's plate on the boat.

Design category B

The boat has been designed for voyages where the following conditions may be experienced:

- Wind force of up to and including 8 on the Beaufort scale (approximately 21 m/s).
- Significant wave height of no more than 4 m.

These conditions may be encountered on offshore voyages or in coastal waters when unsheltered from the wind and waves. These conditions may also occur in inland seas of sufficient size for the wave height to be generated.

Design category C

The boat has been designed for voyages where the following conditions may be experienced:

- Wind force of up to and including 6 on the Beaufort scale (approximately 14 m/s).
- Significant wave height of no more than 2 m, with a temporary peak wave height of 4 m.

These refer to a range from storms to strong winds, with a risk of unexpected waves and gusts. These conditions may be experienced during voyages on large lakes, estuaries, and, in moderate weather conditions, on coastal waters.

Design category D

The boat has been designed for voyages where the following conditions may be experienced:

- Wind force of up to and including 4 on the Beaufort scale (approximately 8 m/s).
- Significant wave height of no more than 0.3 m, with a temporary peak wave height of 0.5 m.

These conditions may be experienced during voyages on sheltered lakes, rivers, and, in good weather, on coastal waters.

3.3 Technical specifications

Technical specifications are for reference only. Always refer to the Declaration of Conformity and your boat's builder's plate for accurate information.

3.3.1 Specification details

Table 3.1 Yamarin 67 DC technical specifications

	Value	Unit
Number of persons	8	persons
Design category	C	A-D
Max load on builder's plate (persons + basic equipment + life raft + stores and cargo)	759 (1673)	kg (lb)
Weight without engine	1686 (3717)	kg (lb)
Total weight of fuel and other liquids in fixed tanks	246 (542)	kg (lb)
Length overall	6.76 (22' 2")	m (ft, in)
Beam	2.55 (8' 4")	m (ft, in)
Estimated height, from waterline, light load	1.55 (5' 1")	m (ft, in)
Estimated draught, loaded	0.40 (1' 4")	m (ft, in)
Max engine power	186 (250)	kW (hp)
Max engine weight	313 (690)	kg (lb)
Fuel tank, volume	195 (51.5)	l (gal)
Max speed reached in seaworthiness tests	46 (53)	knots (mph)
Rated force of mooring points	20.2	kN
Pumping capacity of automatic bilge pump	33 (8.7)	l/min (gal/min)
Pumping capacity of manual bilge pump at 45 rpm	33 (8.7)	l/min (gal/min)
Freshwater tank, volume	70 (18)	l (gal)
Septic tank, volume	30 (7.9)	l (gal)
Max calculated trailer transportation weight	2442 (5384)	kg (lb)

Table 3.2 Constants used in weight calculations

	Value	Unit
Weight of passengers adult/child	75/37.5 (165/83)	kg (lb)
Basic equipment	20 (44)	kg (lb)
Life raft	40 (88)	kg (lb)

3.3.2 Measurements for antifouling paint area



The measurements indicate the upper limit of the antifouling paint, not the true waterline of the boat.

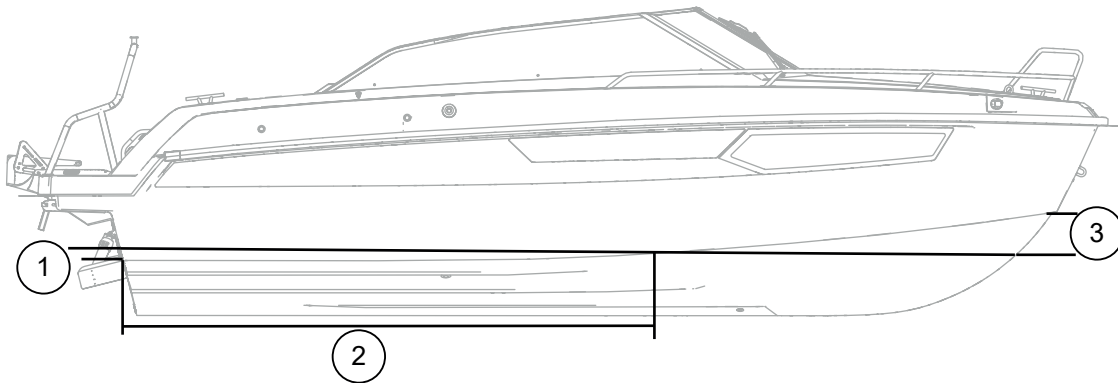

Figure 3.1 Yamarin 67 DC antifouling paint area

Position	Description	mm (in)
1	At stern: directly up from chine	160 mm (6.3")
2	In chine line: from stern	3100 mm (122")
3	At bow: down from chine along the bow	500 mm (20")

4 Structural characteristics

4.1 Stability and buoyancy

The stability of your boat is excellent due to the hull shape and balanced distribution of weight.

However, keep in mind that the stability of the boat can be reduced by the following:

- Large breaking waves.
- Towing or being towed.
- Any load placed above the floor level.
- Freely moving water in the bilge. Make sure the amount of water in the bilge is minimized. See [9 Bilge pumps and draining](#) on page 57.

⚠ WARNING

When loading the boat, never exceed the maximum permitted load stated on the builder's plate.

- Always load the boat carefully and distribute the load so that the boat's design trim angle is not compromised (even keel).
- Avoid placing heavy objects high up.

⚠ WARNING

Any change in the distribution of weight could significantly affect the boat's stability, design trim and performance.

Contact your boat dealer if you are planning such a change.

4.2 Openings in the hull and deck

There are drain holes for the rain water on the boat. Make sure that you:

- Close the drain holes if the boat begins to take on water during loading.
- Keep them open in all other circumstances.
- Check and clean the drain holes regularly to prevent blockage.
- Unscrew the rear plug when the boat is docked or on a trailer. Remember to reattach the rear plug before launching the boat.
- For more information about drainage equipment see [9 Bilge pumps and draining](#) on page 57.

4.3 Seating areas

Your boat has dedicated seats for each passenger. Always use the seats on the boat as shown in the picture.

⚠ WARNING

Risk of capsizing and sinking.

Do not exceed the maximum permitted number of people.

Make sure the total weight of the people and equipment never exceeds the maximum permitted load, regardless of the number of people on the boat.

For details about the limits, see [3.3 Technical specifications](#) on page 26 or the builder's plate on the boat.

4.3.1 Designated seats

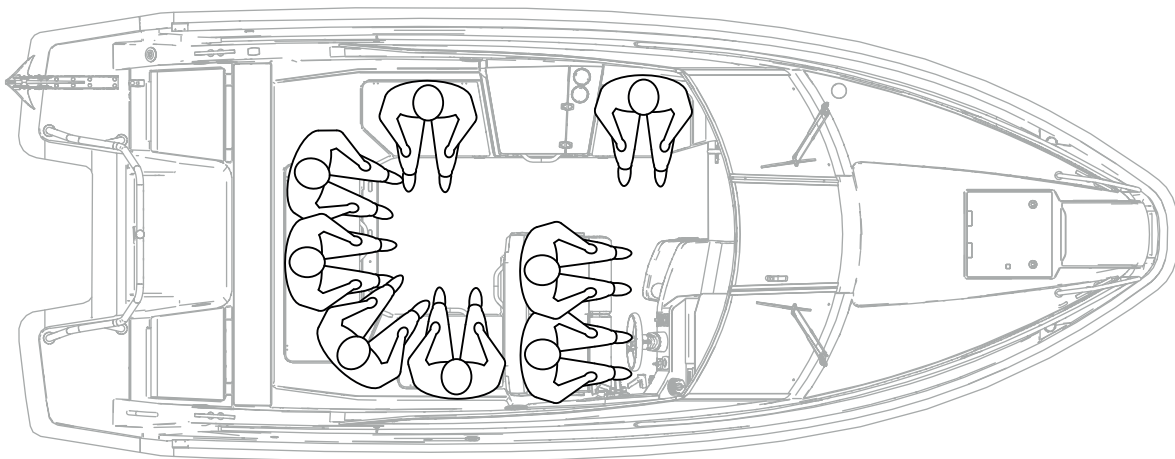

Figure 4.1 Yamarin 67 DC seats for a maximum of eight (8) passengers

4.4 Doors, gates and hatches

4.4.1 Windshield door

Always keep the windshield door closed and locked while driving. Do not use the door as a railing when getting in or out of the boat.

⚠ WARNING

The door may slam shut and cause injury if it is not kept closed when it is not in use.

4.4.2 Cabin door and stairs to the deck

The stairs and cabin door provide easy access to all parts of the boat. The cabin door can be secured to a closed or an open position.

⚠ WARNING

- Do not let children use the cabin door or climb the stairs without adult supervision.
- Keep the cabin door secured when operating the boat to avoid it slamming shut.
- When using the stairs, always maintain three-point support to maintain your balance.
- Be extremely careful when using the stairs, particularly when the cabin door is open.

5 Operation

5.1 Helm station controls

The helm station contains all the necessary control devices for the boat's handling and operation. Familiarize yourself with the controls before using the boat.



Some of the equipment shown in this section is part of optional accessory packages and might not be part of your boat's configuration.

5.1.1 Control device locations

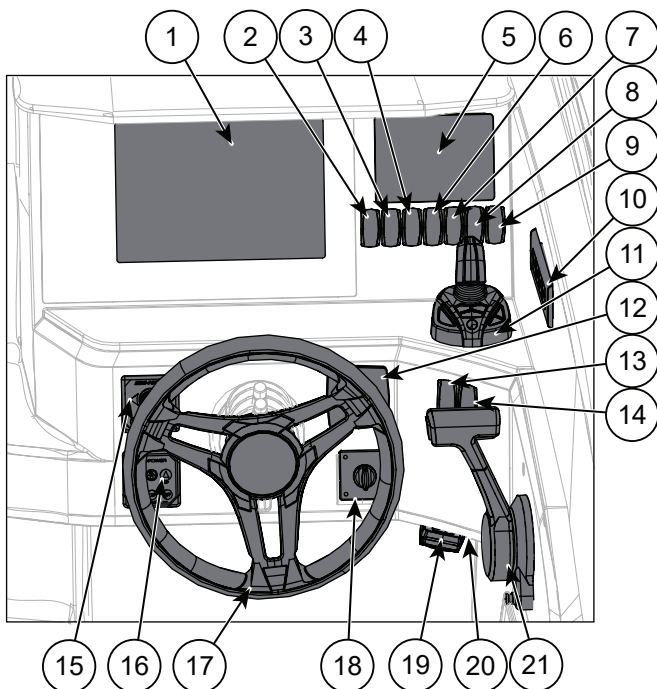

Figure 5.1 Yamarin 67 DC helm station controls

- | | | | |
|----|-------------------------------|----|---|
| 1 | Yamarin Q | 12 | Trim tabs control joystick |
| 2 | Water pump switch | 13 | Signal horn switch |
| 3 | Fridge power switch | 14 | Underwater lights switch |
| 4 | Left windshield wiper switch | 15 | Anchor winch control panel |
| 5 | CL-5 touch screen | 16 | Bow thruster control panel |
| 6 | Right windshield wiper switch | 17 | Steering wheel |
| 7 | Bilge pump switch | 18 | Power and start buttons |
| 8 | Deck lights switch | 19 | Anchor winch and bow thruster remote controller |
| 9 | Navigation lights switch | 20 | USB socket |
| 10 | Autopilot control panel | 21 | Remote control and emergency cut-off switch |
| 11 | Manoeuvring joystick | | |

5.1.2 User instructions for controls

The use of some of the electrical equipment is described in the following sections of this manual, complemented with the manufacturers' own manuals.

The Yamarin Q user manual is integrated into the Q system interface. To open the manual, navigate to Home → Info → Guides.

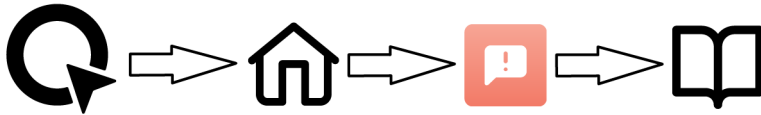

Figure 5.2 Q system user manual

5.2 Driving

As the driver of the boat you are responsible for your own safety and the safety of everyone on board.

⚠ DANGER

Rotating propeller

May cause death or severe injury for persons in the water.

Always stop the engine when a swimmer is approaching the boat or climbing aboard.

Learn the seafaring rules and the COLREG provisions (International Regulations for Preventing Collisions at Sea). Always adapt your speed to the prevailing conditions and pay attention to the following:

- Wave height.
- Comfort of your passengers.
- Your own wake. Observe wake wash prohibitions and reduce your speed to minimize the wake for safety and out of courtesy for others.
- Visibility.
- Familiarity of the route.
- Narrow and crowded waterways.
- The time required for necessary stops and the space for evasive manoeuvres.

5.2.1 Emergency cut-off switch

The engine is set up with an emergency cut-off switch that shuts down the engine if the driver falls overboard or sways out of position. It is crucial that the engine stops if you are driving alone and go overboard or fall down.

⚠ WARNING

Loss of steering control

The release of the cut-off switch stops the engine and causes the boat to slow down rapidly and lose most of the steering control. This may cause people and objects to be thrown forward and result in death or severe injury.

Make sure that all passengers are properly seated while you are driving the boat.

Adjust the cut-off cord length so you can easily reach all control devices without the risk of accidentally releasing the switch.

- Attach the emergency cut-off cord to yourself as soon as you have released the mooring lines.
- Do not attach the cut-off cord to clothing that could tear loose.
- Do not route the cord in a way that could cause it to entangle and stop functioning.
- Detach the cut-off cord before leaving the boat to avoid stopping the engine unintentionally.

Test regularly that the emergency cut-off switch is functioning.

- To make sure that the clip will release, pull the cord in every possible direction.
- Make sure that the clip stays firmly in place but does not need excessive force to come off.

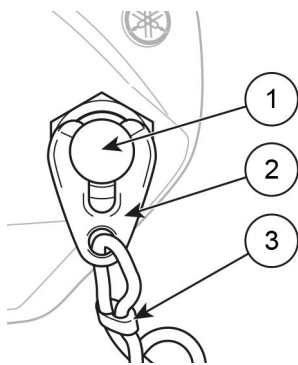

Figure 5.3 Emergency cut-off switch

- | | |
|--|------------------------------|
| <p>1 Engine cut-off switch</p> <p>2 Clip</p> | <p>3 Engine cut-off cord</p> |
|--|------------------------------|

If you notice any issues in the switch operation, contact your local Yamaha dealer for check-up and maintenance.

Refer to the engine manual for more information on the emergency cut-off switch.

5.2.2 Approaching and leaving the dock

Practice boat manoeuvring skills in places where it can be done safely, before entering a crowded marina. The propeller is designed to provide the best thrust in forward gear. This makes the steering response weaker when reversing.

⚠ WARNING

High-speed operation

May cause severe injury or equipment damage.

Reduce speed when approaching stopping areas.

Learn to estimate the distance it takes to safely come to a stop from planing.

Verify you have adequate stopping distance before planing the boat.

When docking:

- Do not try to stop the boat with your hands while docking. Never put your hand or foot between the boat and the dock, the shore or another boat.
- Use sharp but short applications of throttle to generate enough rudder authority.
- Ensure that as many passengers as possible remain seated while docking. Sudden steering movements may cause the boat to heel and cause injury.
- Prepare the mooring lines and fenders at the bow and stern before docking.
- Approach the dock with the bow first at an acute angle. Just before touching the dock, steer into it and shift into reverse.
- Apply throttle quickly and sharply. The boat will stop and turn parallel to the dock.
- Make the approach into the wind or current if possible, whichever is stronger. This makes departing easier.



When securing the boat, take into consideration the prevailing conditions, such as:

- Possibility of changes in wind direction.
- Changes in the water level.
- Waves and wake wash from other boats.

When departing:

- Push the stern as far out from the dock as possible
- Slowly reverse away from the dock into open water.

5.2.3 Visibility from the steering position

It is easy to drive the boat in fair weather when the sea is calm, but always remember to keep lookout as specified in international waterway rules (COLREG). Ensure maximum visibility from the steering position at all times by following these guidelines:

- Position crew and passengers so that they do not obstruct the driver's visibility.
- Do not drive at the planing threshold speed for extended periods as a raised bow blocks forward visibility.
- Use the engine's trim function (power trim), and trim tabs if any, to adjust the bow so that visibility is not compromised.
- Use the windshield wipers when necessary.
- Remember to look behind the boat, especially in fairways where fast vessels may overtake you.

- Give way to faster ships in narrow fairways, especially if they cannot otherwise overtake you safely because of limited space.
- Use the navigation lights during darkness or when visibility is limited for any other reason, such as fog or heavy rain.

5.2.4 Driving at high speed

If the engine has an electro-hydraulic power trim, the basic trim angle adjustments are as follows:

- To plane the boat, adjust the trim all the way down (bow down).
- When the boat is planing in low waves, raise the trim until the boat starts to porpoise, the propeller loses grip or the engine reaches the upper limit of the normal adjustment range. When this happens, lower the bow slightly until the ride is stable. The log (speed indicator) can be used to optimise the trim angle.
- When the boat is riding into waves, lower the bow until the ride becomes smooth. When driving with a tailwind or driving into very high waves the raise the bow slightly to avoid ploughing through the waves.
- Do not drive the boat at a high speed with a fully negative trim angle (bow down) as this may cause the boat to roll from side to side and make steering unstable.

Consult the engine manual for more information.

WARNING

At full speed the boat's handling characteristics may deteriorate.

- Do not drive the boat with the bow too low because this could cause the boat to behave erratically.
- Be very careful when adjusting the trim angle at a high speed: it may radically affect the boat's behaviour.
- Sudden turns at a high speed may result in loss of control. Slow down before sharp turns.
- Waves reduce the boat's manoeuvrability and can cause the boat to swing fromside to side. Reduce the speed when wave height increases.

5.2.5 Operating the joystick

You can use the joystick to manoeuvre the boat more smoothly at slow speeds.

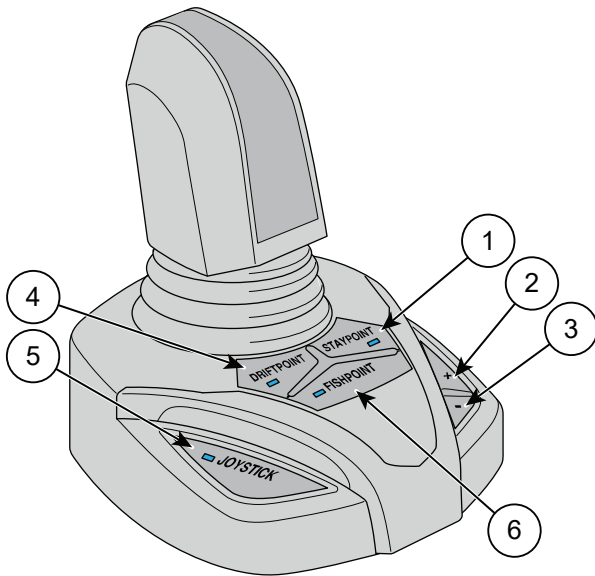

Figure 5.4 Joystick and function buttons

- | | | | |
|---|------------------|---|-------------------|
| 1 | Staypoint button | 4 | Driftpoint button |
| 2 | Plus (+) button | 5 | Joystick button |
| 3 | Minus (-) button | 6 | Fishpoint button |

Activating the joystick

1. Position the remote control and the joystick to neutral position and press the **JOYSTICK** button on the joystick base.
An indicator LED on the button lights up to show that the joystick is active.
2. To return to normal operating mode, press the **JOYSTICK** button again. Alternatively, activate the forward or reverse gear by turning the remote control lever.

Manoeuvring the boat with the joystick

- Push the joystick forward to move the boat forward. Pull the joystick backwards to make the boat reverse.
- Twist the joystick to turn the engine left and right. Turning the joystick left, right or diagonally is not used in single engine applications.
- Use the plus (+) and minus (-) buttons to adjust the engine speed in Driftpoint, Fishpoint and Joystick operation modes. The speed adjustment has five different levels.

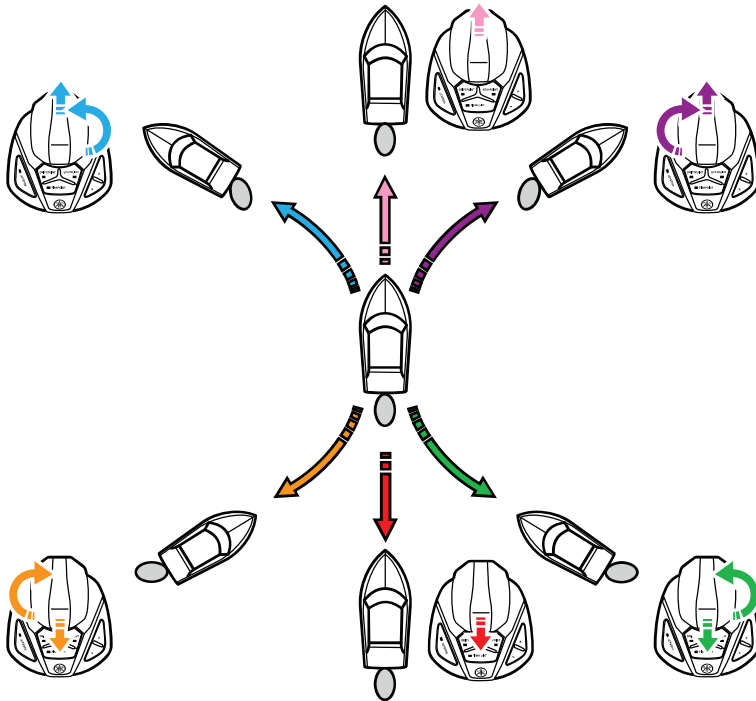

Figure 5.5 Joystick operation with a single engine boat

For more information on the Driftpoint, Staypoint and Fishpoint functions, see the separate Autopilot user manual.

You can calibrate the joystick via the CL-5 display. For more information, see the CL-5 user manual.

For more detailed instructions on the joystick, see the Joystick Quick Guide that is delivered with your boat.

5.2.5.1 Integrated bow thruster controller

Your boat can be equipped with a feature that allows you to control the bow thruster using the Yamaha joystick.

Activating the integrated controlling

1. On the autopilot panel, press **F1** button.
2. Activate the joystick by positioning the remote control and the joystick to neutral position and pressing the **JOYSTICK** button on the joystick base.

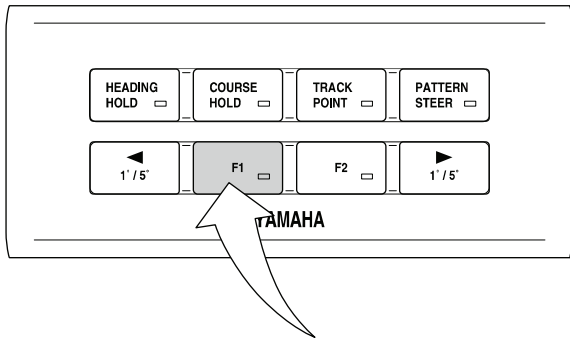

Figure 5.6 Autopilot control panel

- When the integration is activated, you can control the bow thruster with both the bow thruster controller and the Yamaha joystick.
- If the control devices are used simultaneously, the one with a larger input value is dominant. If the inputs from the two devices are in opposite directions, the bow thruster is not affected.
- The **F1** button stays activated until you switch it off. This allows you to switch to an alternative helm station or joystick station, if applicable, and use the integration from there.

Controlling joystick with bow thruster integration

The joystick control differs from normal use when the integration is activated.

To operate the bow thruster, twist the joystick to desired direction while keeping the joystick in neutral position.

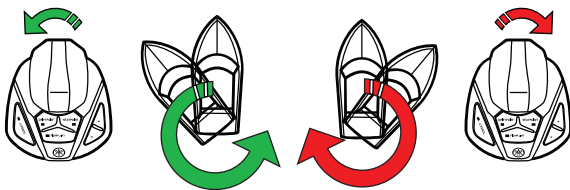

Figure 5.7 Bow thruster operation

- To manoeuvre the boat forward or backward, push or pull the joystick in desired direction.
- Push the joystick diagonally in corner position to aim the engine’s thrust towards the set direction.
Then add twisting motion to adjust the direction of the bow.
- The controls are proportional, so you can add as much of force to the thruster as you wish. When done correctly, the boat can almost travel sideways.
- Use the plus (+) and minus (-) buttons to adjust the engine speed in five levels.
- To return to normal operating mode, press the **JOYSTICK** button again. Alternatively, activate the forward or reverse gear by turning the remote control lever.

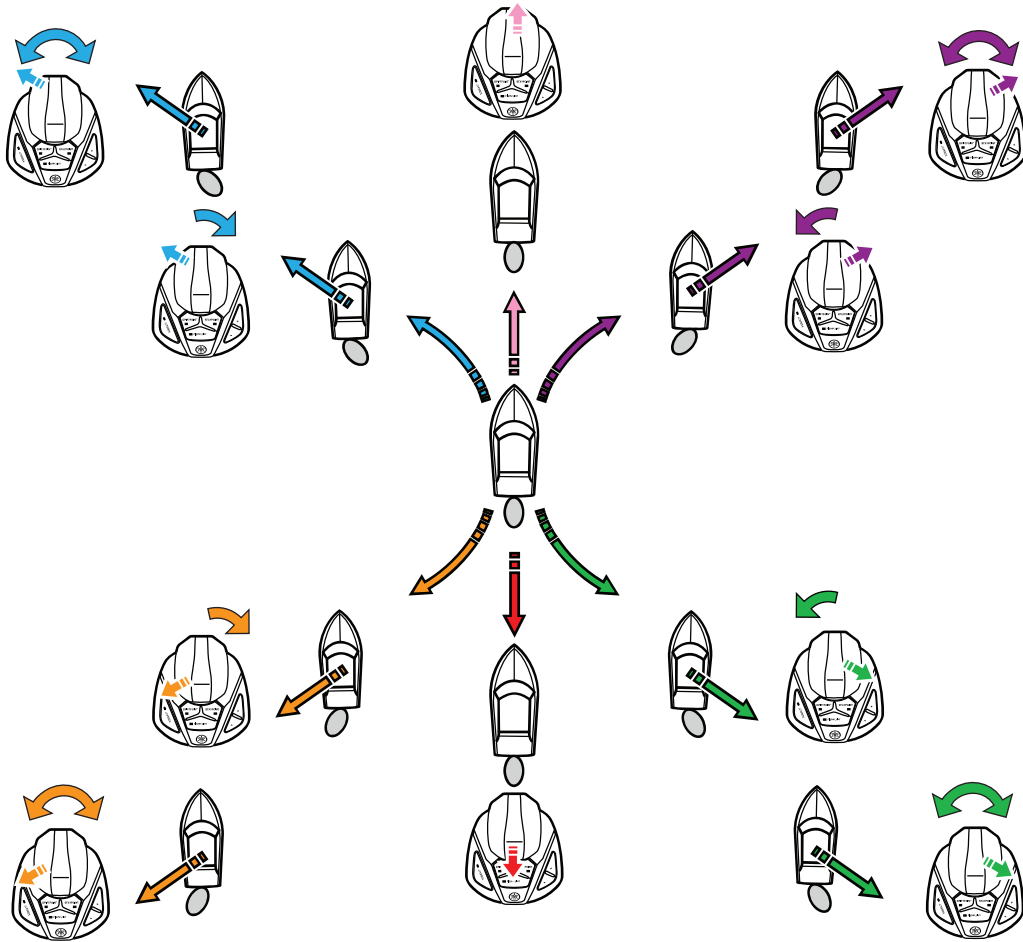

Figure 5.8 Joystick operation with integrated bow thruster control

5.2.6 Adjusting the trim tabs

Use the trim tabs to balance the boat's heel when travelling in a crosswind or with an unbalanced load. Note the following:

- When the boat is planing it will lean into the wind. Lower the windward trim tab to counteract this.
- To further reduce the waves' effect on the boat, trim the windward side up. This will lift the boat slightly above the waves.

⚠ WARNING

- Too rapid adjustments change the way the boat behaves. Adjust the trim tabs carefully when driving at high speeds.
- Waves reduce manoeuvrability and make the boat heel. Reduce the speed when driving in large waves.

5.2.6.1 Trim system components

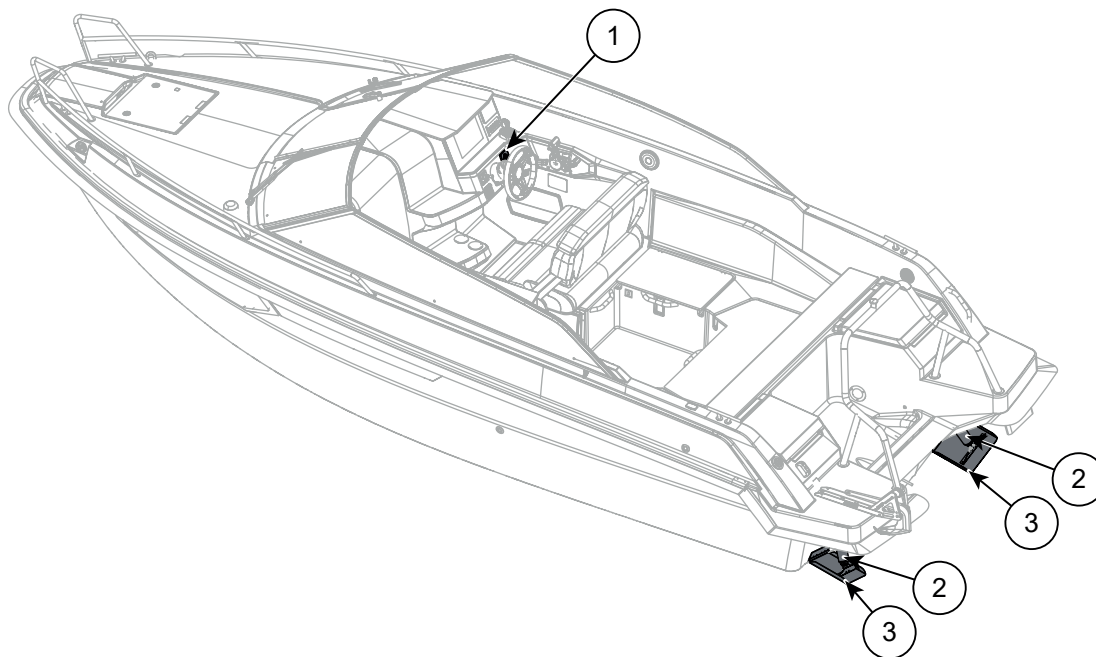

Figure 5.9 Yamarin 67 DC trim system

- | | |
|---|-------------------|
| <p>1 Trim controls</p> <p>2 Trim cylinder</p> | <p>3 Trim tab</p> |
|---|-------------------|

5.3 Mooring, anchoring and towing

When you are mooring, anchoring or towing the boat, use only the mooring points shown in the picture. Ensure that the lines, ropes and chains, as well as the anchors, are suitable for their intended use.

⚠ WARNING Risk of injury

Never try to stop the boat by hand or place your hand or foot between the boat and the pier, shore or another boat.

Practise mooring in fair weather. Use engine power sparingly but resolutely.

Your boat has either a hardened bow eye for locking and trailering, or a bow eye for trailering and a separate hardened locking eye on the deck.

- Use the bow eye for winching the boat onto a trailer or sliding dock, and use the hardened locking eye for locking the boat.
- If your boat has a single hardened bow eye, you can use it for both winching and locking.

NOTICE

Risk of material damage.

The bow and locking eyes are only intended for trailering and locking the boat.

Do not use the eyes for any other purpose, such as mooring or towing, or other use that could cause lateral stress.

Mooring

- Use mooring lines, ropes and chains with a breaking strength that do not exceed 80 percent of the rated strength of the mooring points. See [3.3 Technical specifications](#) on page 26.
- Use mooring ropes equipped with shock-absorbing springs.
- Avoid mooring with the stern against the wind as high waves may crash over the stern.
- Take into account potential changes in the wind direction, changes in water level, waves and wake wash from other boats.
- Use sufficiently large fenders to prevent abrasion.

NOTICE

Do not use the mooring points for lifting the boat.

Anchoring

- Make sure the depth is sufficient when anchoring at a natural harbour and anchor sufficiently far from the shore.
- For the anchor to get a good hold ensure that the length of anchoring line equals 4 to 5 times the depth. To increase the hold further, release more rope.
- You can increase the hold of the anchor significantly by using weighted rope or chain on the first 3 to 5 meters of the anchoring line.

Towing

- Use a sufficiently strong, floating towing line when towing another boat.
- Start towing gently and avoid shocks.
- Do not overload the engine.
- When towing a small dinghy, adjust the line length so that the dinghy rides on the downhill slope of your wake.
- In narrow straits and high waves, bring the dinghy closer to the transom to stabilise its movement.
- Fasten all equipment in the dinghy in place securely in case the dinghy capsizes.
- When on the open sea, cover the dinghy to prevent flooding due to spray and splashing from waves.

⚠ WARNING

If the towing line snaps, the loose end could cause death or serious injury.

Always use a sufficiently strong towing line and avoid being directly in front of the towing line.

5.3.1 Attachment points

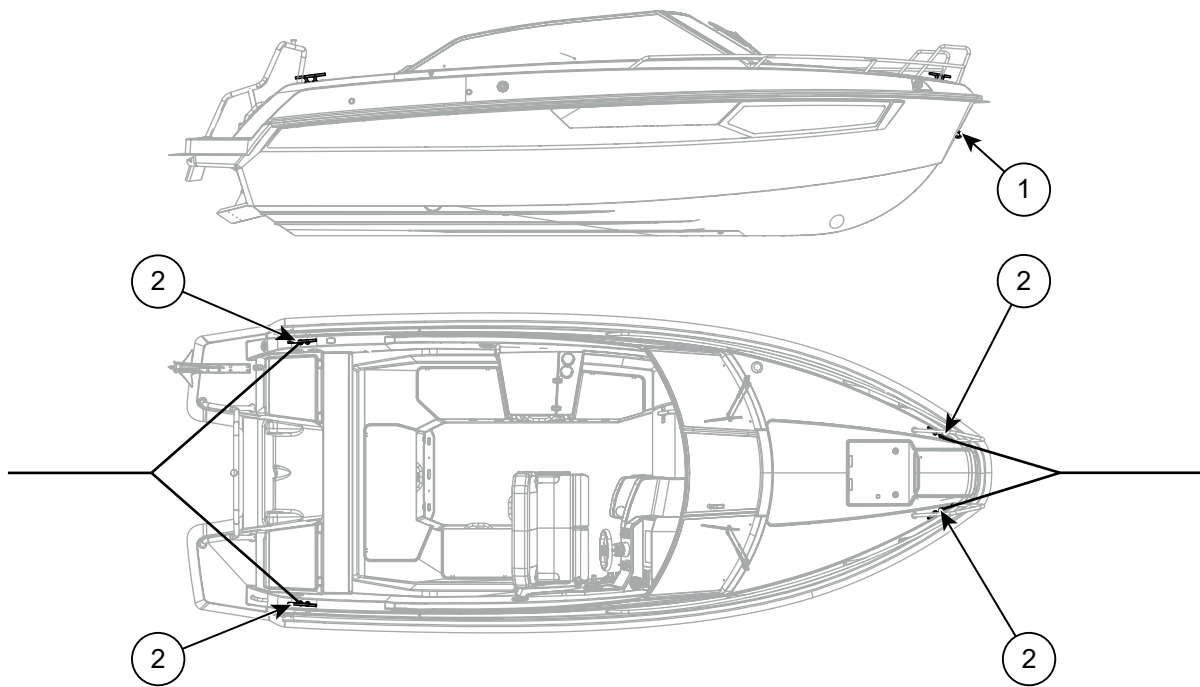

Figure 5.10 Yamarin 67 DC mooring and towing points

- 1 Hardened eye for locking and trailering
- 2 Mooring points

6 Fuel system

The boat has a fixed fuel tank attached to the bilge area, close to the transom.

⚠ WARNING Do not modify the fuel system.
Modifications can lead to overflow.



The fuel meter indication on the helm station screens is for reference only. Make sure you carry enough fuel to reach your destination.

6.1 Fuel system components

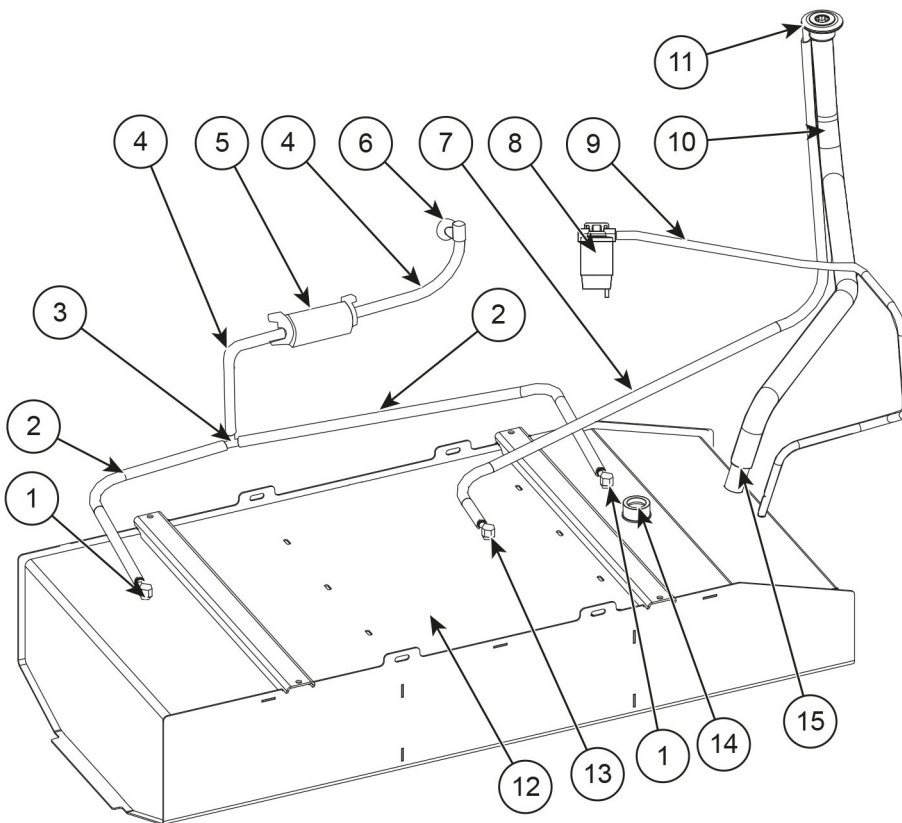

- | | | | |
|---|----------------------------------|----|-------------------|
| 1 | Tank vent valve | 9 | Suction hose |
| 2 | Breather hose | 10 | Filler hose |
| 3 | Y-valve | 11 | Fuel filler |
| 4 | Breather hose | 12 | Fuel tank |
| 5 | Carbon canister | 13 | Fill limit valve |
| 6 | P-trap and breather through vent | 14 | Fuel sensor |
| 7 | Breather hose | 15 | Inlet check valve |
| 8 | Fuel filter | | |

6.2 Refueling and maintenance

For the location of the fuel inlet, see [2.3 Safety labels](#) on page 11.

WARNING

Risk of fire! Take extra caution when refueling:

- Before filling the fuel tank, stop the engine and extinguish any naked flames and cigarettes.
- Do not operate any electrical equipment when refueling.
- If you refuel your boat at a petrol station, do not use a plastic funnel that prevents the static charge between the pistol and the fuel inlet from discharging.
- After filling the tank, make sure that no fuel has spilled into the bilge. Clean up any splashes of fuel immediately.

For maintenance:

- Check the fuel lines annually for wear and tear.
- Regularly check the fuel filter to ensure that there is no water in the moisture trap, which is located under the filter.
- Change the fuel filter 1-2 times a year depending on the engine hours and quality of fuel.

6.3 Fuel-operated equipment

The boat is equipped with a diesel fuel tank for powering fuel-driven equipment. Depending on the availability of options for your boat model, the boat may be equipped with:

- Stove
- Heater with a single heating unit that functions as an air heater
- Water heater with a combi heating unit that functions as an air heater as well as a water heater

6.3.1 Fuel-operated equipment components

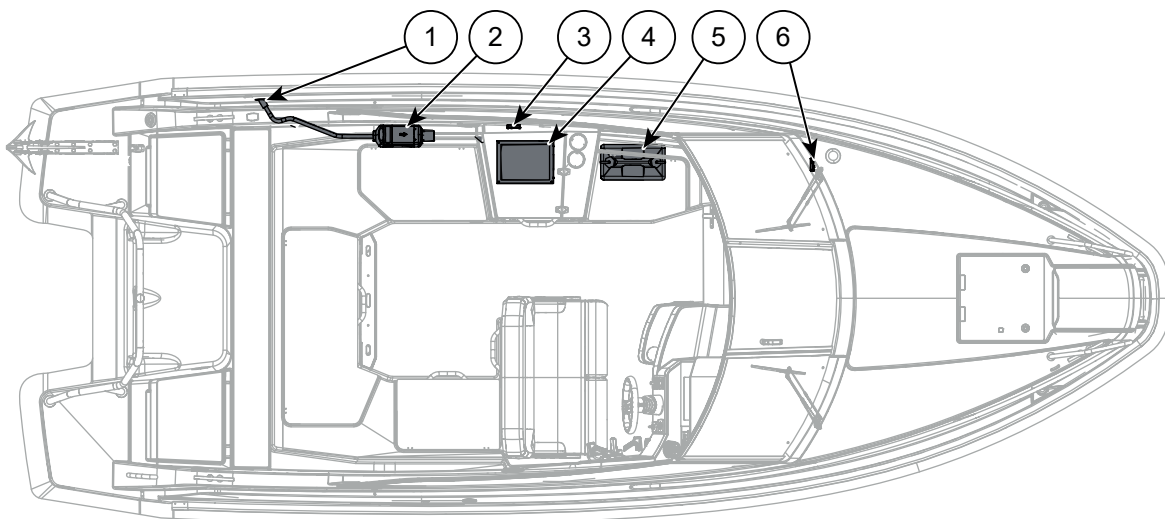

Figure 6.1 Yamarin 67 DC fuel-operated equipment

- | | | | |
|---|---------------------|---|----------------------|
| 1 | Heater exhaust | 4 | Stove |
| 2 | Heater | 5 | Diesel tank |
| 3 | Stove control panel | 6 | Heater control panel |

6.3.2 Heater

The diesel heater is an optional feature and its operation is described in a separate manufacturer's manual. It is connected to an on/off type fuse, which also functions as a main switch for the device. The location of the heater and heater controls are presented in the image in section [6.3 Fuel-operated equipment](#) on page 45.

- Always turn off the heater when refueling.
- Clean up any fuel spills immediately.

NOTICE

Do not close the heater's warm air vent when it is switched on. This can cause the heater to overheat and engage the overheat protection.

6.3.3 Stove

The stove is an optional feature and its operation is described in a separate manufacturer's manual. It is connected to an on/off type fuse, which also functions as a main switch for the device. The location of the stove and stove controls are presented in the image in section [6.3 Fuel-operated equipment](#) on page 45.

- The stove utilizes the same diesel tank as the heater. Always turn off the heater when refuelling.
- Do not use the stove in rough seas.
- Do not use the stove if any faults are found.

⚠ WARNING

Fire hazard.

- Keep the stove's cover plate in the open position when the stove is hot.
- Let the stove cool down properly before closing the cover.

NOTICE

The edges of the stove's glass cover are vulnerable to hard knocks and impacts.

- Ensure that nothing in the sink or on the stove obstructs the cuddy cover before lowering it.
- Keep the cover closed and secured when the boat is moving.

7 Engine

The engine has its own manual that is provided with the boat. Refer to engine manual for more detailed instructions of use and proper maintenance.

7.1 Starting engine

The ignition is controlled either by a button or key, depending on the boat model or accessories.

1. Switch on the power using the main power switch.
2. Lower the engine into the driving position by pressing the power trim button on the gear/throttle handle.
If the power trim button is not available, lower the engine manually.
3. Check that the gear is in the neutral position and that the emergency switch is attached to the bottom of the remote control.
4. Switch on the ignition using the power button/key on the steering console and wait a few seconds for the warning lights to light up.
5. Start the engine by pressing the start button/turning the key until the engine starts. The engine should start within 1-2 seconds. Do not try to start the engine for more than 10 seconds at a time.
6. Let the engine idle for a few minutes before setting off.

Read the engine manual for more detailed information about the engine.

7.2 Using gearshift and throttle

The remote control functions as a throttle, forward and reverse gearshift and the engine trim angle controller.

NOTICE

Risk of material damage.

Do not shift into reverse while travelling at higher speeds as this damages the engine.

- Put the engine into gear by pushing the button on the gear/throttle handle upward and by pushing or pulling the handle forward or backwards.
- When the engine is in gear, adjust the speed using the gear/throttle handle.
- When the boat is travelling forward at a slow speed, you can use the reverse gear for braking.

For more information on using the remote control, see a separate equipment manufacturer's manual.

8 Electrical system

8.1 System description

The boat is equipped with a 12 volt electrical system.

The boat's electrical components vary depending on the equipment level. For details, see section [8.5 Electrical equipment](#) on page 53.

Most of the controllers for the equipment are located at the helm station. For more details, see [5.1 Helm station controls](#) on page 32.

In addition, the engine is an essential part of the boat's electrical system; it both generates and consumes power.

⚠ WARNING Do not alter the boat's electrical system or associated diagrams. Only a skilled boat electrician is allowed to modify and service the system.

8.2 Main switch and fuse panel

The main switch and fuse panel are located as indicated in the diagram. Every battery in the boat's electrical system has its own dedicated main switch.

The main switch has the symbols **○** = off and **I** = on. Switch off the current using the main switch:

- When leaving the boat unattended.
- Before performing any electrical installation or maintenance work.

⚠ WARNING Improper alteration of overcurrent device ratings
May cause injury or equipment damage.
Never alter or modify the rated current amperage of overcurrent protective devices

⚠ WARNING Improper component amperage
May cause injury or equipment damage.
Never replace electrical appliances or devices with components which exceed the rated current amperage of the circuit.
Verify component rating before installation.

NOTICE Electrical fault
If a fuse keeps popping after being reset, consult a qualified marine electrician.



The automatic bilge pump and the Q-system remote operation circuits remain operational whenever the battery is attached to the electrical system, regardless of the position of the main switch.

The boat uses automatic fuses, which enable the current to be switched back on following a circuit overload. If a button has popped up, switch the current back on by pressing the button down.

Depending on the model and equipment level, the boat's electrical system has 1–3 redundant circuits equipped with fuses. These circuits can be used for retrofitting additional equipment. The identifiers and the names of the fuses are shown in the wiring diagrams available in the manual appendices.

8.2.1 Switch and fuse descriptions

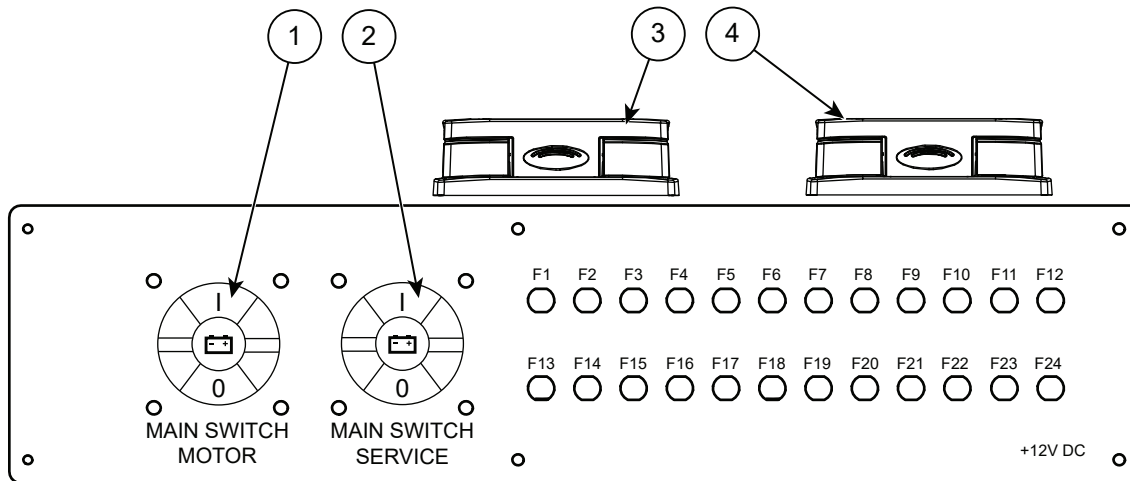

Figure 8.1 Yamarin 67 DC main switches and fuse panel

1	Main switch motor		F11	Stove *	10 A
2	Main switch service		F12	Yamarin Q	10 A
3	Isolator fuse	100 A	F13	Windshield wipers	10 A
4	Main fuse	80 A	F14	Shower pump/pantry tap	10 A
F1	Fridge *	20 A	F15	Solar panel	10 A
F2	Heater *	15 A	F16	Cabin spot lights	5 A
F3	Bilge pump	10 A	F17	Trim tabs	20 A
F4	Fishfinder	10 A	F18	Power steering	40 A
F5	Water pump/Deck lights	10 A	F19	Septic tank gauge	3 A
F6	Navigation lights	10 A	F20	Cabin led lights	10 A
F7	Audio	25 A	F21	Extra	10 A
F8	12 V outlet/USB socket	10 A	F22	Underwater lights	10 A
F9	NMEA	3 A	F23	Signal horn	5 A
F10	Extra	10 A	F24	Audio amplifier	50 A

* These fuses are on/off type fuses, and they function as a main switch for the related equipment

8.3 Double-battery system

The boat can be equipped with a double-battery electrical system:

- The primary battery is the engine battery.
- The secondary battery is a service battery intended for use when the engine is switched off and there is no charging current available.
- Each battery has a main switch controlling the connection to the boat's electrical system.



It is recommended that you keep both batteries on when the boat's engine is started and the boat is in motion. Both batteries are charged when the engine is on.

To use the boat's electrical system with the engine turned off:

- Turn off the engine main switch. This disconnects the engine battery from the system.
- The engine battery will remain charged even if the service battery is entirely discharged while the boat is stationary.

For charging, disconnecting and replacing the batteries, see [8.4 Maintaining batteries](#) on page 52.

The wiring diagram for the double-battery system is shown in the wiring diagrams available in the manual appendices.

8.4 Maintaining batteries

Proper battery maintenance is important for a safe use of your boat. Service the batteries regularly and follow their charge status in order to prevent them from discharging. You can follow the batteries' state of charge from the tachometer or Q-monitor, if applicable.

WARNING

Risk of injury.

Incorrect battery handling can cause serious damage to your boat or injury to passengers.

Consult a qualified electrician if necessary.

Charging batteries

The boat's batteries charge automatically when the engine is on. You can also recharge batteries externally.

NOTICE

Risk of material damage.

Switching off the main switch while the engine is running can damage the charger. Recharging a battery with excessive current may cause the battery to explode.

Never switch off the main switch while the engine is running. Recharge the batteries only using the boat's engine or charger appropriate for the battery type.

Ensure that the battery does not leak and spill battery acid into the boat when recharging.

Disconnecting batteries**NOTICE**

Risk of material damage.

When connecting or disconnecting batteries, make sure that no metal tools make contact with the aluminium parts of the boat or both terminals of the battery simultaneously.

The batteries need to be disconnected when:

- You want to deactivate the automatic bilge pump.
- In connection with maintenance and winter lay-up.
- When replacing batteries.

Replacing batteries

Requirements for new batteries:

- The engine battery should be capable of producing large currents.
- The service battery, if equipped, should be a deep-cycle battery with high-energy density, such as an AGM, gel, or lithium-ion battery.
- If you are using a special type of battery, take note of any specific requirements in terms of connections, charge regulators, and protection from water.

8.5 Electrical equipment

The configuration of the electrical equipment on your boat may vary. Some of the equipment shown is part of optional accessory packages and might not be part of your boat's configuration.



Inspect the electrical equipment and electrical system at least twice a year.

8.5.1 Locations of electrical equipment

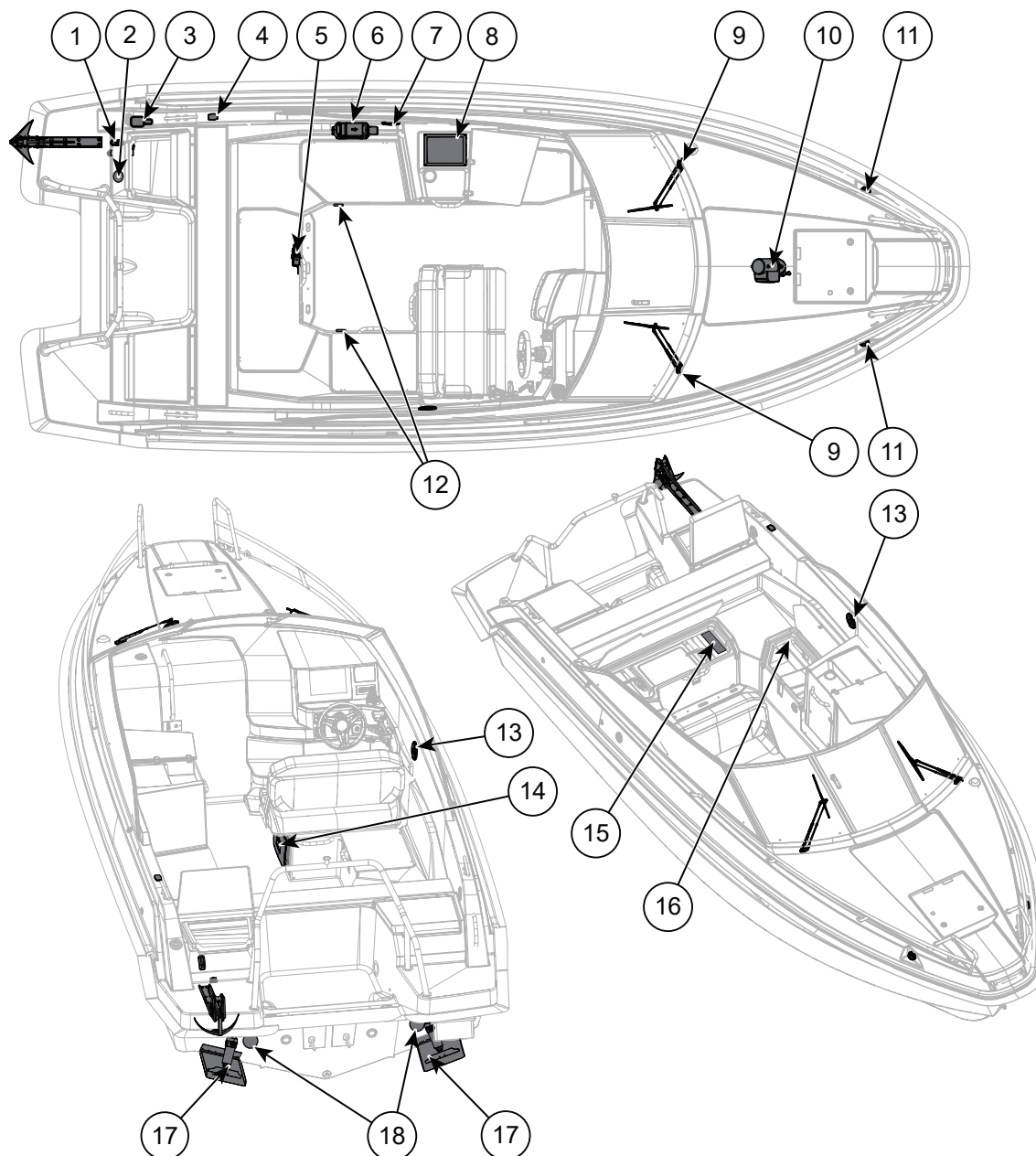

Figure 8.2 Yamarin 67 DC electrical equipment

- | | | | |
|---|-------------------|----|----------------------------|
| 1 | Anchor winch | 10 | Bow thruster |
| 2 | Shore power inlet | 11 | Navigation lights |
| 3 | Water pump | 12 | Deck lights |
| 4 | Light mast | 13 | Loudspeaker |
| 5 | Bilge pump | 14 | Fridge |
| 6 | Heater | 15 | Main switch and fuse panel |
| 7 | 12 V outlet | 16 | Shore power RCD |
| 8 | Stove | 17 | Trim tabs |
| 9 | Windshield wipers | 18 | Underwater lights |

8.5.2 Shore power

The boat can be equipped with shore power.

⚠ DANGER

Energised AC system

Electric shock may cause death or serious injury.

Disconnect the shore power when it is not in use.

Verify the system is de-energised before performing any work.

⚠ WARNING

Power cable contact with water

Connecting the shore power cable may energise the water around the boat and cause death or serious injury to nearby swimmers.

Do not allow any part of the power cable to hang in the water.

Note the following when using shore power.

- Connect metallic housings or enclosures of installed electrical appliances to the protective conductor system in the boat.
- Only use double-insulated or grounded (earthed) electrical appliances.
- Do not alter shore power cable connectors. Only compatible cable connectors and shore power receptacles.
- Test the operation of the RCD (Residual Current Device) monthly.

8.5.2.1 Connecting shore power

Connect the shore power in the correct order to minimise the risk of electric shock and fire.

The shore power system is equipped with an RCD that functions as the system main switch.

1. Connect the shore power cable to the boat's inlet first.
2. Connect power cable to the shore power source.

If the reverse polarity indicator activates, turn off the RCD switch immediately and correct the polarity fault before activating the boat's electrical system.

To disconnect shore power, unplug the power cable from the shore power source first.

Close the cover of the shore power inlet tightly when the power cable is disconnected.

8.5.3 Cabin lights

The cabin light switch is located on the cabin ceiling, on the left side of the door when entering the cabin.

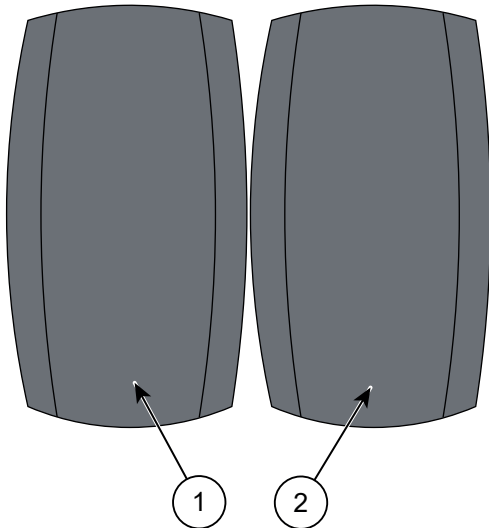

Figure 8.3 Yamarin 67 DC cabin light switch

- 1 Ceiling light switch
- 2 Wall light switch

8.5.4 Navigation lights

Your boat is equipped with the following navigation lights:

- Fixed navigation lights in the bow.
- White anchor light on a removable light mast in the stern.

For the location of the lights, see *Locations of electrical equipment*.

NOTICE

Risk of material damage.

If the boat is equipped with a telescopic light mast, store it in the retracted position to avoid bending it.



The rules and regulations on the use of lights when boating can differ locally. Check your local regulations before leaving the port. As a rule of thumb, it is better that you have the lights on than off.

Always check that the lights are functioning before you leave the port. Replace defective lights as soon as possible.

If you install additional lights on the boat, make sure that they do not interfere with the visibility of the standard-regulated anchor and navigation lights. Do not modify the anchor or navigation lights in any way.

9 Bilge pumps and draining

The bilge pump removes excess water that accumulates in the bilge during the boat operation.

Depending on the model and equipment level, your boat can be equipped with automatic electric and/or manual bilge pump(s).

WARNING

Risk of flooding

The bilge pump system is not designed to control water ingress caused by running aground or other structural damage.

Make sure that at least one bucket or bailer is kept on board. It must be attached to the boat with a rope to prevent loss.



Some smaller boats that are designed to be emptied using a removable pump or a bailer may not have a bilge pump installed as a standard equipment. If you wish to install a bilge pump on a boat that is not equipped with one, contact an authorised service.



Regularly inspect the bilge pumps and clean their suction heads of any waste. You can access the pump through the bilge pump service hatch.

To ensure stability it is important that the amount of water in the bilge is kept to a minimum. It is, however, natural that the bilge always contains a small quantity of water that the bilge pumps cannot remove.

9.1 Electric pump

The automatic bilge pump drains water from the bilge when the surface sensor detects water:

- The pump activates when the sensor has been fully submerged for 10 seconds.
- It deactivates when the sensor has been dry for more than two seconds.
- The pump is always on standby when the battery is connected, regardless of the position of the main switch.
- The pump has a signal device that gives out an audio signal when the pump is running.

NOTICE

If the bilge pump is running constantly it could indicate a leak in the hull.

Do not disconnect the bilge pump when the boat is in the water.

You can also activate the automatic pump manually:

- The switch is located in the steering console.
- This switch is equipped with a light that turns on when the pump is operating.

- If the light does not activate, check the fuse of the bilge pump.
- If the fuse is intact and the pump still does not start, consult an authorized dealer for repairs.

9.2 Manual pump

The manual bilge pump and its operation are described in a separate manufacturer’s manual that is delivered with the boat.

The manual pump achieves maximum pumping capacity when it is operated at a rate of 45 rpm.

9.3 Locations of draining equipment

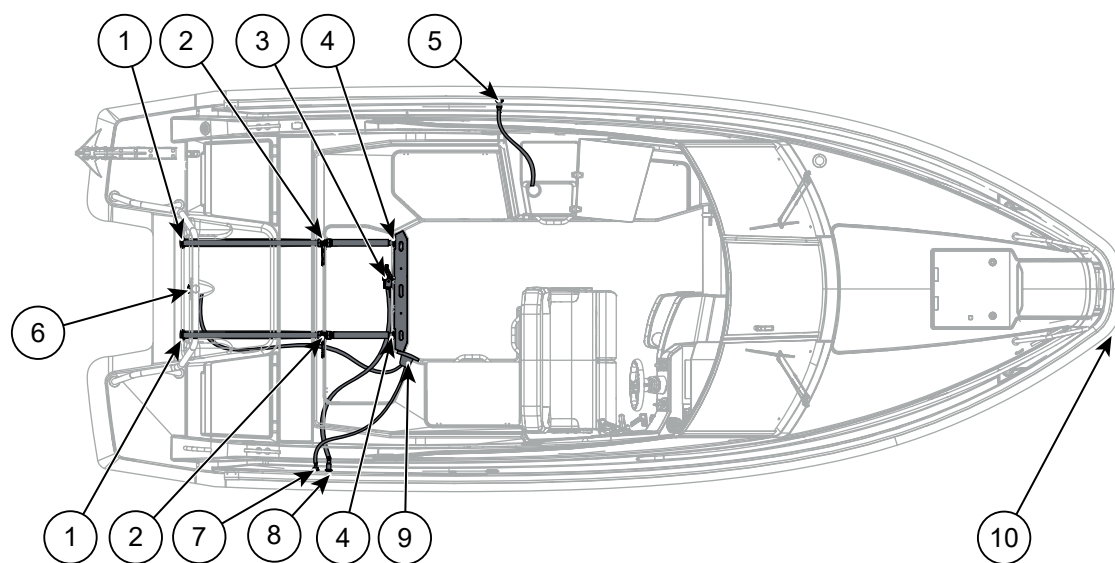

Figure 9.1 Yamarin 67 DC bilge pumps and draining

- | | | | |
|---|--------------------------------------|----|-------------------------------------|
| 1 | Shut-off flap | 6 | Rear plug |
| 2 | Rainwater drainage shut-off valve | 7 | Manual bilge pump through fitting |
| 3 | Electric bilge pump and float switch | 8 | Electric bilge pump through fitting |
| 4 | Rainwater drainage through fitting | 9 | Manual bilge pump |
| 5 | Pantry sink drainage through fitting | 10 | Rope box drainage through fitting |

10 Freshwater system

The freshwater system consists of the following components.

- Fixed freshwater tank
- Water pump
- Water heater (Available optionally for some boat models)
- One or several water outlets depending on the boat's equipment level.

The outlets can include a deck shower, pantry tap and toilet tap.

NOTICE

Risk of material damage.

Leftover water in the system may freeze during winter lay-up and cause damage to the system.

Always empty the freshwater system if you leave the boat unused for longer periods of time. Use pressurized air to empty the hoses completely if necessary.



Disinfect the freshwater system annually. Consult your local boat dealer on suitable chemicals for disinfecting plastic fresh water tanks and follow the instructions given.

The inlet of the freshwater system is indicated with blue colour and with the text **WATER**. The capacity of the water tank is specified in [3.3 Technical specifications](#).

Check the inlet's O-ring seal for wear every time you fill the water tank. Change the seal if necessary.

The freshwater system is a closed system, and heat can cause a biofilm to appear on the inner surface of the tank and the hoses.

- Clean the system if the water tastes or smells bad, or if it is dirty.
- Also clean the system thoroughly if algae or slime is found on the inner surfaces of the tank or hoses.

10.1 Freshwater system components

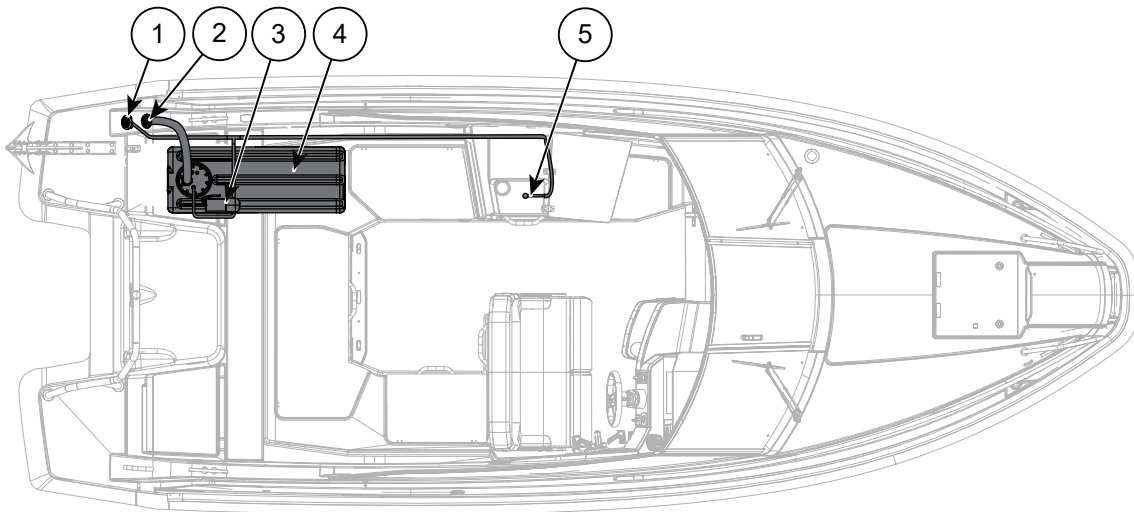

Figure 10.1 Yamarin 67 DC freshwater system

- | | | | |
|---|-------------|---|------------|
| 1 | Deck shower | 4 | Water tank |
| 2 | Water inlet | 5 | Pantry tap |
| 3 | Water pump | | |

11 Accessories

11.1 Toilet and septic tank

The boat's toilet is flushed with sea water and the flushing waste is conveyed into the septic tank.

NOTICE

Environmental hazard.

Discharging the septic tank into the sea is harmful to marine life and against responsible seamanship in many countries.

Plan your trip so that you have access to the septic services at ports.

Find out local regulations about the handling of marine waste water before emptying the tank into the sea.

- Drain the septic tank when leaving port by using the port's drainage equipment.
- The septic tank can also be drained into the sea using the sea drainage valve. Keep the valve closed under normal conditions. The valve can be sealed.
- Clean the septic tank, the hoses and other components with a mild alkaline detergent.
- Keep the system as empty as possible when storing the boat in freezing conditions. Use glycol as an anti-freeze agent if necessary.
- It is recommended to keep the toilet's seawater intake valve closed when the toilet is not in use.

11.1.1 Septic system components

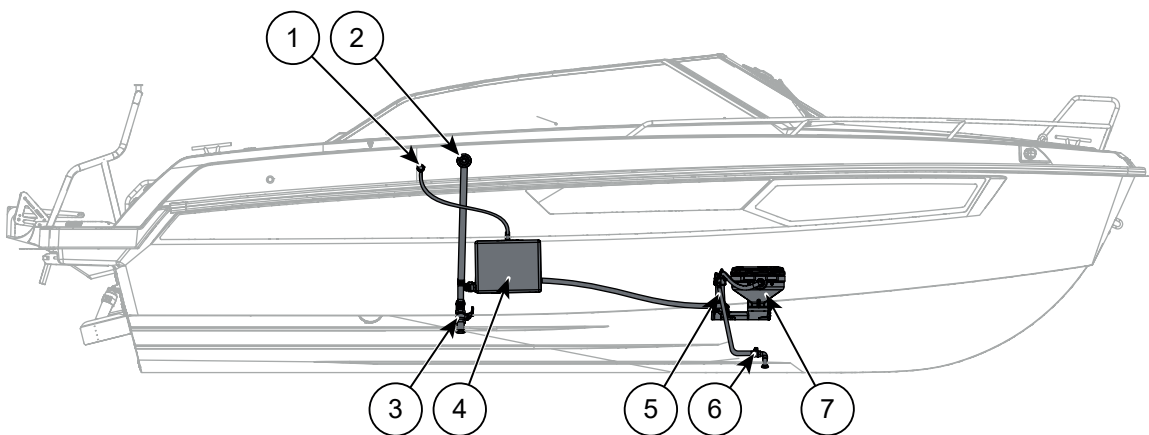

Figure 11.1 Yamarin 67 DC septic system

- | | | | |
|---|--------------------------------------|---|------------------------------------|
| 1 | Septic tank breather through fitting | 5 | Manual toilet flushing pump |
| 2 | Septic tank vacuum drain fitting | 6 | Toilet flushing water intake valve |
| 3 | Septic tank sea drainage valve | 7 | Toilet |
| 4 | Septic tank | | |

11.2 Anchor winch

The boat can be equipped with an electrically operated anchor winch, which is located on the aft deck of the boat.

- The anchor winch deploys and retrieves the anchor using a rope.
- It is controlled from a control panel or with a separate remote controller depending on the equipment level of the boat.
- The winch is equipped with a safety line for securing the anchor when it is not in use.

11.2.1 Anchor winch system components

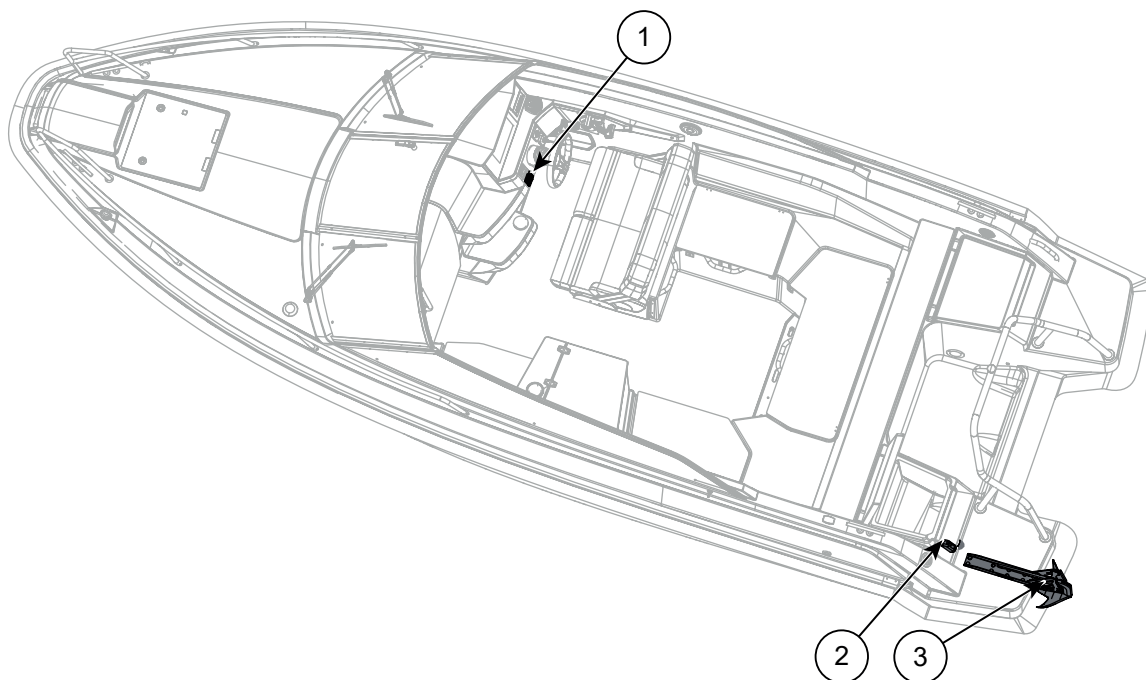

Figure 11.2 Yamarin 67 DC anchor winch

- | | |
|--|--------------------------------------|
| <p>1 Anchor winch control panel</p> <p>2 Winch</p> | <p>3 Anchor and anchor guide</p> |
|--|--------------------------------------|

11.2.2 Using the anchor winch

To deploy the anchor, release it using the control panel or, if applicable, the remote control.

To retrieve the anchor:

- Reel up the anchor from the control panel or the remote control.
- Secure the anchor to the boat using the safety line. Adjust the safety line length so that it is tight enough to keep the anchor from moving but is still easy to remove when needed.

⚠ WARNING

Dropping the anchor while the boat is moving can cause death or serious injury. To avoid the anchor falling unintentionally:

- Always secure the anchor with the safety line when the boat is moving or the anchor is not in use.
- Never attach the safety line to the winch. Attach it to a fixed point on the boat.

The anchor guide top roller should sit firmly on top of the anchor. Regularly check the roller position and adjust if necessary by tightening the anchor guide top roller with the adjustment screw:

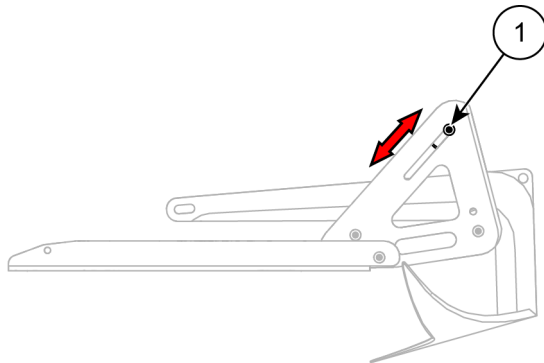

1 Anchor guide top roller

NOTICE

Do not overtighten the guide roller. This can break the roller or prevent the winch from functioning properly.

- When the anchor is reeled up, make sure the winch rope is tight, but does not cause excessive force to the winch or anchor guide.
- If the anchor does not fully reel up or reels up too tight, adjust the end-stop sensor rings on the anchor rope.

Salt water can cause the anchor rope to stiffen up. Rinse the rope regularly with fresh water to keep the winch functioning properly.

See the provided anchor winch manual for more detailed instructions on how to operate the winch.

11.3 Bow thruster

Depending on your boat's optional accessories, it may be equipped with a bow thruster.

- The bow thruster assists you in manoeuvring the boat at slow speeds. It enables you to move the bow sideways without using the main engine.
- The thruster is operated from a control panel or joystick. For the location of controls, see [5.1 Helm station controls](#) on page 32.

NOTICE

Equipment damage hazard.

Using the bow thruster continuously for long periods of time can blow the thruster fuses and/or damage its motor.

Use the thruster in short bursts to turn the bow in the desired direction.

For more information on the bow thruster, see a separate equipment manufacturer's manual.

11.4 Canopy

Depending on the model and accessories, the boat might be equipped with a canopy. The canopy is designed to withstand a maximum speed of 30 knots at sea, and 50 km/h in road transport. Fasten all press studs properly when using the canopy. You can raise the canopy fully, or raise just the front part.

To stow the canopy in its box:

1. Remove the sides and back of the canopy to make it fit in the box more easily.
2. Fold the upper parts of the sides entirely on top of the roof. Make sure that no fabric remains where the corners of the canopy supports are.
3. Roll up the roof part along with the sides folded on top of it, and lower the canopy into the box.

NOTICE

Do not drive the boat in the rain with the canopy down. The equipment in the open-deck area is not watertight and must be protected from rain.



The seal between the windshield and the canopy is not necessarily watertight.

11.5 Bimini

Instead of a canopy, the boat can be equipped with a bimini top. The bimini is designed to withstand a maximum speed of 7 knots. Always lower the bimini during road transport.

To raise the bimini:

1. Loosen the sliders on the sides of the boat by turning the thumb screws.
2. Lift the bimini out of the canvas garage and slide it to the bow end of the sliders.
3. Tighten the sliders with the thumb screws.
4. Lift the bimini up and attach the straps on the front corners to the eyelets on the windshield frame.
5. Attach the aft corner straps to the fittings near the end of the windshield frame.
6. Tighten the straps so that the bimini becomes tight and firm.

To lower the bimini follow the steps in reverse order.

11.5.1 Raised bimini

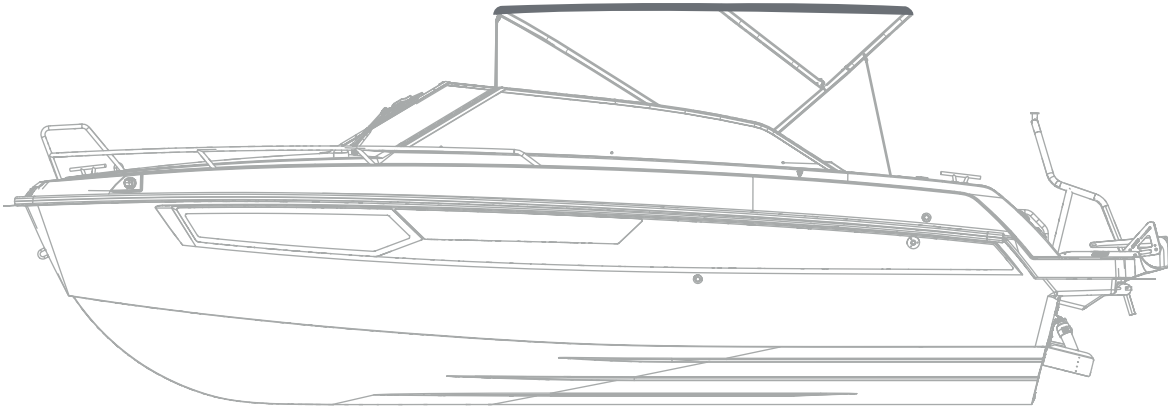

Figure 11.3 Yamarine 67 DC bimini

12 Environmental considerations

The seas, lakes and archipelago are unique and it is a matter of honour for boaters to preserve their natural habitats. Avoid the following:

- Fuel and oil leaks.
- Discharge of waste or rubbish into the water or onto the shore.
- Discharge of detergents or solvents into the water.
- Emptying the septic tank into the sea.
- Causing loud noise, whether out on the water or in harbour.
- Causing wake wash, especially on narrow straits and shallow waters.

Always adhere to the applicable environmental laws and regulations. Familiarise yourself with the provisions of the International Convention for the Prevention of Pollution from Ships(MARPOL).

12.1 Requirements for North America

The EPA standards state that in freshwater lakes, freshwater reservoirs or other freshwater impoundments whose inlets or outlets are such as to prevent the ingress or egress by vessel traffic subject to this regulation, or in rivers not capable of navigation by interstate vessel traffic subject to this regulation, marine sanitation devices certified by the U.S. Coast Guard installed on all vessels shall be designed and operated to prevent the overboard discharge of sewage, treated or untreated, or of any waste derived from sewage.

The EPA standards further state that this shall not be construed to prohibit the carriage of Coast Guard certified flow-through treatment devices which have been secured so as to prevent such discharges.

They also state that waters where a Coast Guard-certified marine sanitation device permitting discharge is allowed include coastal waters and estuaries, the Great Lakes and interconnected waterways, freshwater lakes and impoundments accessible through locks, and other flowing waters that are navigable interstate by vessels subject to this regulation (40 CFR 140.3).

12.2 Aquatic invasive species (AIS)

Aquatic invasive species (AIS) are plants and animals that occur in waters in which they are not native and whose introduction may cause economic or environmental damage, or harm to human health. AIS have a negative impact on waterways, native species, as well as on recreational and commercial uses of waterways.

As responsible boaters and citizens, each boat owner should do their part to prevent the spread of these aquatic hitchhikers. In many cases, it is also required by law. Check local regulations for waterways where you plan to go boating.

To stop the spread of AIS, follow these three steps after each boating trip: Clean, Drain, and Dry. This helps protect the environment from the damage that AIS can cause.

Clean

Inspect the boat, engine, trailer, anchor and watersports equipment, and remove all aquatic plants, animals, mud and debris from them.

Rinse, scrub or wash the boat away from storm drains, ditches or waterways. Rinse the boat, trailer and equipment with hot water, when possible. Flush the engine according to the owner's manual.

Drain

Completely drain all water from the boat and its compartments, including but not limited to:

- Bilge, wells and lockers.
- Ballast tanks or bags, and bait containers.
- Engines and engine outdrive units.

Dry

Allow the boat to dry completely before putting it back into the water.



Some localities may require inspection or decontamination before launching or after retrieving a boat from the water, or both. Check what the state and local laws require before you go boating.

Additional recommendations

Before taking the boat out of the water, inspect and clean:

- Motor or engine, including the gimbal area.
- Trailer, including axles, bunkers and rollers.
- Anchors, dock lines and equipment.

Also, drain live wells, bait containers, ballast and bilge tanks, and engine cooling systems.



STOP AQUATIC HITCHHIKERS!

Be A Good Steward. Clean. Drain. Dry.

StopAquaticHitchhikers.org

13 Maintenance, repairs and docking

Information on boat maintenance, winter storage, servicing, and repairs is available on the website at www.yamarin.com or from your local dealer.

Consult an authorized dealer for information on repairing large aluminium areas or treating damaged surfaces. In the event of engine failure or problems with other equipment, the primary point of contact is the manufacturer of the equipment in question.

⚠ WARNING

Only a qualified electrician is allowed to repair the electric system.

NOTICE

If performed incorrectly, retrofits or alterations may cause damage to the boat's structures, expose it to galvanization or spontaneous corrosion, or endanger safety.

- Only use cleaning agents, surface treatments, and paints that are compatible with the materials of your boat.
- Consult an authorized dealer before you make any new electrical connections, hatches, holes, install any equipment, or combine any other metals or alloys with aluminum.

13.1 Maintenance tasks

13.1.1 Before winter lay-up

It is important that you perform the following actions before winter storage:

- Wash the hull and bottom immediately after lifting the boat out of the water.
- Unscrew the rear plug and make sure all other drainage devices are open.
- Make sure there is no water left in the bilge or inside the bilge pumps to avoid freezing. Run the pumps to empty them if necessary, but do not let the automatic pump overheat.
- Remove all cushions and store them indoors in a dry place. Make sure to leave the cabin well ventilated.
- Wash the rear and front decks.
- Remove the batteries and store them in a warm, dry place.
- If the boat is equipped with a refrigerator, winterize it according to the equipment manufacturer's manual.
- Also see the available manufacturer's manuals for other equipment to determine if they require specific preparations before winter storage.

13.1.2 Before launching

Perform these actions before launching the boat:

- If you have stored the boat under a tarpaulin, remove it in good time before launching.
- Wash the hull and bottom with a suitable detergent and a soft brush.
- Paint the bottom with antifouling paint if the boat is to be used in salt water.
- Put the batteries back and check the electrolyte levels in the cells. Check the condition and charge levels of the batteries.
- Check all cables, clamps, engine mountings and other fastenings.
- Check the steering and instrumentation before launching.
- Make sure that all drainage devices are tight and in order. Check that there is no frost damage.
- Check the condition of anodes and replace them if necessary.

13.2 Care instructions

NOTICE

Risk of material damage.

Heavy or extreme weather conditions can cause water to get through the console seams.

Always cover the boat with a harbour cover, canopy, or similar cover if such weather conditions are expected.

13.2.1 Washing and waxing the boat

Keeping your boat clean will help prevent dirt from staining the surfaces, make it easier to maintain your boat and reduce the overall amount of maintenance required.

- For normal cleaning, fresh water and a soft brush or sponge are usually sufficient. Use special boat care products or mild general purpose cleaning agents if needed.
- Rinse off any bird droppings from the boat's surfaces and canopy as soon as possible. Brush off dried bird droppings and clean them using fresh water and a mild detergent if needed.
- Wash the exterior hull immediately after lifting the boat out of the water, as it is easiest to remove any algae and dirt when the hull is still wet. Use a pressure washer or brush with fresh water.
- If the hull has been treated with anti-fouling paint, wash the surface and remove the paint by wet-grinding. Collect any grinding dust to protect the environment.

Consult your local dealer for information on the correct cleaning agents for the boat.

13.2.1.1 Fiberglass surfaces

- Wax protects the boat's fiberglass surfaces and makes it easier to keep clean. Clean your boat thoroughly after the boating season and apply wax to the fiberglass surfaces before the start of the next boating season.
- Before applying wax, wash the fiberglass surfaces using a pressure washer, brush or sponge. Use mildly abrasive polishing agents to remove chafing and embedded dirt. Use cleaning agents containing oxalic acid or phosphoric acid to remove the stains around the waterline.
- Remove any fuel splashes immediately from the boat's surfaces.

13.2.1.2 Aluminium surfaces

- For aluminium parts, use only cleaning agents that are specifically meant for aluminium surfaces. Do not use alcohol-based agents, solvent-based agents or cleaning agents that contain acids.
- Wash painted aluminium surfaces using the same cleaning agents that are suitable for aluminium in general.
- Remove chafe, oxidation, and stubborn stains from non-surface treated aluminium surfaces mechanically using fine-grade abrasive polish. Protect the aluminium surfaces after abrasive polishing using waxing products or protective oil.
- Protect aluminium surfaces above the waterline using a thin layer of protective oil for aluminium or similar multipurpose oil. Spray the oil onto the surface of the boat and wipe with a dry cloth.
- Wax the surfaces after polishing as wax protects the clean surface from getting dirty again and maintains the shine longer. Do not use abrasive polishing or wax products on anodized aluminium surfaces, such as fittings and railings. Waxing also protects painted and shiny metal surfaces.
- The removal of oxidation marks from aluminium surfaces is not necessary since oxide protects the metal naturally.
- Before winter storage, spray a generous layer of protective oil onto the aluminium surfaces, but do not wipe it off. Instead, leave the oil on the surface and wipe it clean only in the spring. This will also remove any dirt and dust that has accumulated during winter storage.
- Do not use abrasive polishing or wax products on anodized aluminium surfaces, such as fittings and railings.

13.2.1.3 Stainless steel surfaces

- Clean and wax the boat's stainless steel parts, such as rails, handles and bollards at least twice every season to keep them shiny. Also clean the edges of the mounting flanges of the rails as any dirt that remains under the edge of the flange will begin to look like rust.
- Carry out these maintenance measures also before putting the boat into winter storage.

13.2.1.4 Plastic surfaces

- Do not apply solvent-based cleaning agents to the consoles and other plastic components.
- Use only non-abrasive mild detergents.

13.2.1.5 Windshield

The boat's windshield is made of tempered glass. Clean it with ordinary glass cleaners.

- Avoid circular motions when wiping the windshield dry after cleaning. This can create smudges which become visible in sunlight and impede visibility.
- Wipe off any streaks with dry newspaper or cotton cloth using first horizontal, then vertical motions.

13.2.2 Marine upholstery

Follow these instructions in order to best care for and preserve the boat's upholstery.

Sunlight

The materials are designed for marine use and the surface is UV-protected, but long-term exposure to UV-radiation will fade the colours and shorten the service life of the materials.

Avoid storing cushions in direct sunlight for extended periods of time.

Humidity

Although the open cell plastic foam inside the cushions is protected with plastic, fungal growth may form on the inner surface of plastic foam and artificial leather.

- Do not store the cushions so that they are exposed to constant humidity.
- Do not let the cushions become waterlogged.

Frost

Avoid transporting, storage or use in temperatures under -20°C , as the surface of the material may rip.

Care and protection

To clean the upholstery:

- Wipe the upholstery with a damp cloth moistened with a neutral washing liquid; for example, dishwashing liquids or window-cleaning products diluted with water.
- It is a good idea to dry the cushions after washing.
- Remove more persistent dirt and stains by dissolving them with undiluted neutral washing detergent. Rinse and dry them afterwards.

Avoid the following:

- Solvents and petrol.
- Grease and motor oil.
- Abrasive cleaning equipment and scouring agents.
- Strong alkaline and acid cleaning products.
- Sharp and hot objects.
- Colouring liquids.
- Protective or conserving agents not intended for artificial leather.

13.2.3 Storing the canopy

Store the canopy over winter in a dry and well-ventilated place. The warranty does not cover torn or mouldy canopies.

13.2.4 Adjustable seats

If your boat is equipped with adjustable seats, periodically inspect them to identify potential wear or damage.

- Ensure that any sliding mechanisms are clear of debris to maintain smooth operation.
- If you detect issues, consult the seat manufacturer's manual and have the seats inspected by a professional.

13.2.5 Electronic remote control device

If there is a problem in the functioning of the electronic remote control device, it must be serviced at an authorised Yamaha workshop.

13.2.6 Steering system

Depending on the model and selected accessories, the boat can be equipped with either hydraulic, electrical, or mechanical steering.



If you replace any component in the steering system, note that all components must conform to the ISO 10592 standard and carry the CE mark.

Hydraulic steering

The hydraulic steering wheel's position changes constantly, which is why the boat is equipped with a symmetrical steering wheel.

The hydraulic steering does not require maintenance under normal circumstances. However, if the steering starts to feel loose, there is a leak in the system.

⚠ WARNING

A hydraulic steering system that has a leak or trapped air in the hoses is extremely dangerous.

Have leaks repaired immediately.

Electrical steering

Electrical steering is maintenance free in normal conditions, but like any steering system should be checked for correct functionality regularly.

Mechanical steering

Have the uncovered parts of the mechanical steering system cleaned and greased during maintenance.

If the mechanical steering starts to feel stuck, take the boat in for professional servicing.

13.2.7 Electrical components

Electrical components such as main switches, other switches and connections do not normally need to be serviced if the boat is stored in a dry and well-ventilated place for the winter.

If, however, you wish to protect electrical components against oxidation, spray them every now and then with a moisture-repellent antioxidant.

13.3 Trailer transportation and lifting

Trailer transportation

Before loading the trailer:

- Make sure you do not exceed the boat's calculated trailer transport weight. See [3.3 Technical specifications](#) on page 26.
- Remove all excess load and pump out as much bilge water as possible.
 - Drain out any water left in the bilge through the rear plug when the boat is out of the water.
 - Remember to reattach the plug before launching the boat.
- Make sure the trailer is suitable for the boat and has a sufficient number of support guides to reduce point loads.

WARNING

Traffic hazard.

Using an unsuitable or poorly maintained trailer can endanger safety and lead to a traffic accident.

Always use a well-maintained trailer that is rated for the boat's weight.

NOTICE

Risk of material damage.

When transporting the boat on a trailer, the movement of the trailer can cause the boat to shift unexpectedly.

To minimize the risk of damage, do not overtighten the fastening straps.

NOTICE

Risk of material damage.

When the boat is out of the water in hot weather, the fuel in the tank evaporates. This can cause the tank to expand and result in fuel leaks.

Make sure the tank is not completely full when the boat is out of the water.

Placing the boat on the trailer:

- Adjust the trailer's longside support guides so that the main weight of the boat rests on the keel support.
- Use only the trailer eye on the bow for pulling the boat onto the trailer as the mooring points are not designed for this.
- If you want to lift the boat, take extra caution. See *Lifting* in this section for more details.

- Fasten the boat securely to the trailer before transporting the boat on the road. Always use trailer hooks, if provided, to secure the boat to the trailer. Insert pads between the boat and fastening straps to protect the boat.
- Use two separate fastening straps at the aft. Do not tie the boat with one fastening strap going over it.
- Ensure that the pulling force of the fastening straps is directed correctly.
At the bow, down and towards the aft. At the aft, down and towards the bow.

Before road transportation:

- Raise the engine all the way up.
- Make sure that there are no loose items on the boat that can fall off during transport.



- Make sure your towing vehicle has high enough rated towing capacity for the loaded trailer. See the vehicle's registration certificate for its towing capacity.
- Make sure your driver's license allows you to drive the combination of your vehicle and trailer.
- When towing the trailer the weight should rest slightly on the towing bar.

After transportation, wash off any salt or grime that may have accumulated on the hull to prevent corrosion.

Lifting

WARNING

Safety risk.

Serious injury or death may occur if the boat falls when it is being lifted.

Never go under the boat when it is being lifted.

When lifting the boat, consider the following:

- Only use a professional crane operator for lifting the boat.
- Make sure that the crane and lifting implements have sufficient lifting capacity.
- Do not use chains for lifting. Only use straps.
- Make sure the straps go under the keel when lifting. Never lift the boat using the mooring points.

13.3.1 Placement on the trailer

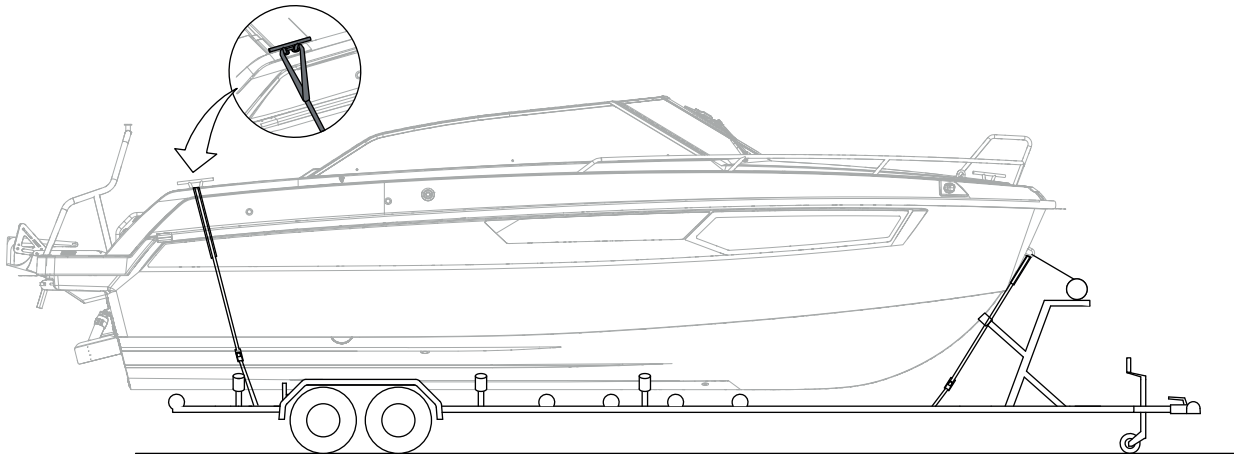

Figure 13.1 Yamarin 67 DC trailer transportation

14 Related documents

The following documents are available as part of the owner's manual appendices.

- Declaration of conformity

This document certifies that the boat meets all relevant standards and regulations. Ensure that the Declaration of Conformity form is filled in with the Watercraft Identification Number (WIN) of your boat, or that you obtain a separate form filled in by your dealer at the time of purchase.

- Wiring diagrams

These diagrams provide detailed information on the boat's electrical system, which is essential for maintenance and troubleshooting.